

# PCG-505F/505FX

## SERVICE MANUAL

*US Model  
Canadian Model*

**Ver 2-2001C**

All the supplementary information are attached at the end of data files.

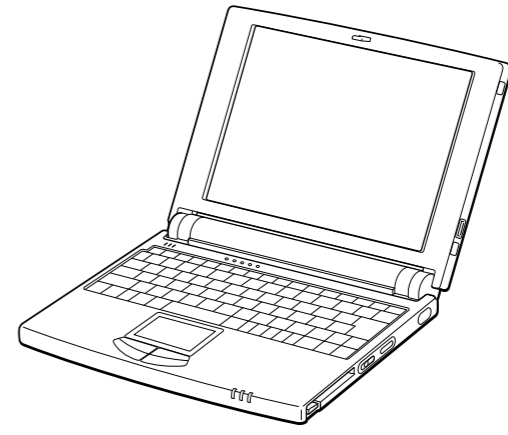

English  
98X11XXX-1  
Printed in XXX  
© 1998. X  
XXXXXXX

Notebook Computer  
**SONY**®

**Sony Corporation**  
XXXXXXX

**Information in this document is subject to change without notice.**

Sony and VAIO are trademarks of Sony. Intel logo and Intel Inside logo are registered trademarks of Intel Corporation. Pentium MMX is a trademarks of Intel Corporation. Microsoft, MS-DOS, Windows, the Windows 95 and Windows 98 logo are trademarks of Microsoft Corporation.

All other trademarks are trademarks or registered trademarks of their respective owners. Other trademarks and trade names may be used in this document to refer to the entities claiming the marks and names of their products. Sony Corporation disclaims any proprietary interest in trademarks and trade names other than its own.

Caution Markings for Lithium/Ion Battery - The following or similar texts shall be provided on battery pack of equipment or in both the operating and the service instructions.

CAUTION: Danger of explosion if battery is incorrectly replaced. Replace only with the same or equivalent type recommended by the manufacturer. Discard used batteries according to the manufacturer's instructions.

CAUTION: The battery pack used in this device may present a fire or chemical burn hazard if mistreated. Do not disassemble, heat above 100°C (212°F) or incinerate.

Dispose of used battery promptly.

Keep away from children.

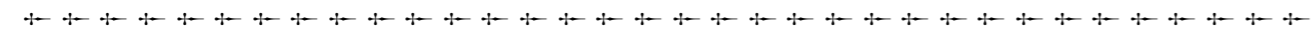

## Service and Inspection Precautions

### 1. Obey precautionary markings and instructions

Labels and stamps on the cabinet, chassis, and components identify areas requiring special precautions. Be sure to observe these precautions, as well as all precautions listed in the operating manual and other associated documents.

### 2. Use designated parts only

The set's components possess important safety characteristics, such as noncombustibility and the ability to tolerate large voltages. Be sure that replacement parts possess the same safety characteristics as the originals. Also remember that the ( $\Delta$ ) mark, which appears in circuit diagrams and parts lists, denotes components that have particularly important safety functions; be extra sure to use only the designated components.

### 3. Always follow the original design when mounting parts and routing wires

The original layout includes various safety features, such as inclusion of insulating materials (tubes and tape) and the mounting of parts above the printer board. In addition, internal wiring has been routed and clamped so as to keep it away from hot or high-voltage parts. When mounting parts or routing wires, therefore, be sure to duplicate the original layout.

### 4. Inspect after completing service

After servicing, inspect to make sure that all screws, components, and wiring have been returned to their original condition. Also check the area around the repair location to ensure that repair work has caused no damage, and confirm safety.

### 5. When replacing chip components...

Never reuse components. Also remember that the negative side of tantalum capacitors is easily damaged by heat.

### 6. When handling flexible print boards...

- The temperature of the soldering-iron tip should be about 270C.
- Do not apply the tip more than three times to the same pattern.
- Handle patterns with care; never apply force.

Caution: Remember that hard disk drives are easily damaged by vibration. Always handle with care.

# TABLE OF CONTENTS

## CHAPTER 1. REMOVAL

1-1.	Flowchart .....	1-1
1-2.	Electric Parts Arrangement Diagram .....	1-1
1-3.	Removal .....	1-2
1.	Palm rest housing assembly .....	1-2
2.	Keyboard unit, touch pad, SWX-19 board .....	1-2
3.	HDD .....	1-3
4.	SWX-20 board, IRC-4 board, CNX-44 board, CNX-45 board and CNX-25 board .....	1-3
5.	MBX-13 board, speaker unit, and nickel-hydrogen battery .....	1-4
6.	PC card connector, heat pipe, and heat sink .....	1-4
7.	Display assembly .....	1-5
8.	Housing bezel assembly, LCD unit, and inverter .....	1-5

(to 1-5)

## CHAPTER 2. SELF-DIAGNOSTICS

2-1.	Note .....	2-1
2-2.	Necessary Tools .....	2-1
2-3.	Start-up of the Self-Diagnostics Program .....	2-1
2-4.	Diagnostics on the Setup Screen .....	2-1
2-5.	Diagnostics Using the Self-Diagnostics Program .....	2-2
2-6.	Test Items .....	2-3
2-7.	Tests that are not Supported .....	2-5

(to 2-5)

<b>CHAPTER 3. BLOCK DIAGRAM .....</b>	<b>3-1</b>
---------------------------------------	------------

(to 3-2)

<b>CHAPTER 4. FRAME HARNESS DIAGRAM .....</b>	<b>4-1</b>
---	------------

(to 4-2)

## CHAPTER 5. EXPLODED VIEW AND PARTS LIST

5-1.	Main Unit .....	5-1
5-2.	Display Unit .....	5-3
5-3.	FDD Assembly .....	5-5

(to 5-6)



## 1-1. Flowchart

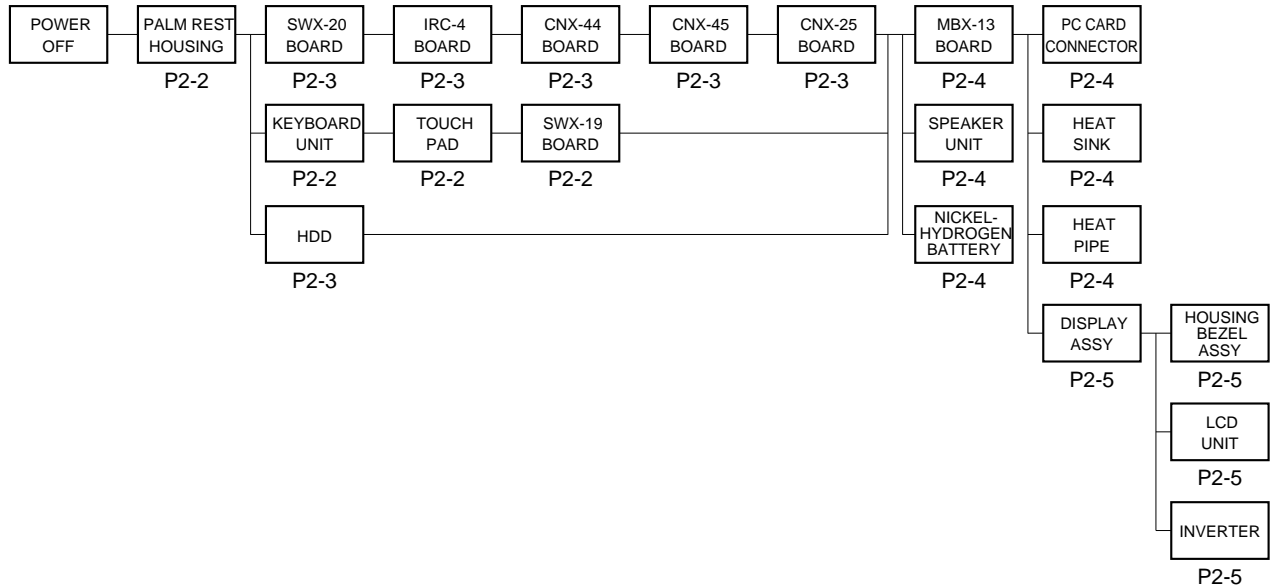

- Page x-x indicates the page for the topic.
- Note that HDDs (Hard Disc Drives) are easily damaged by shock of impact.

## 1-2. Electric Parts Arrangement Diagram

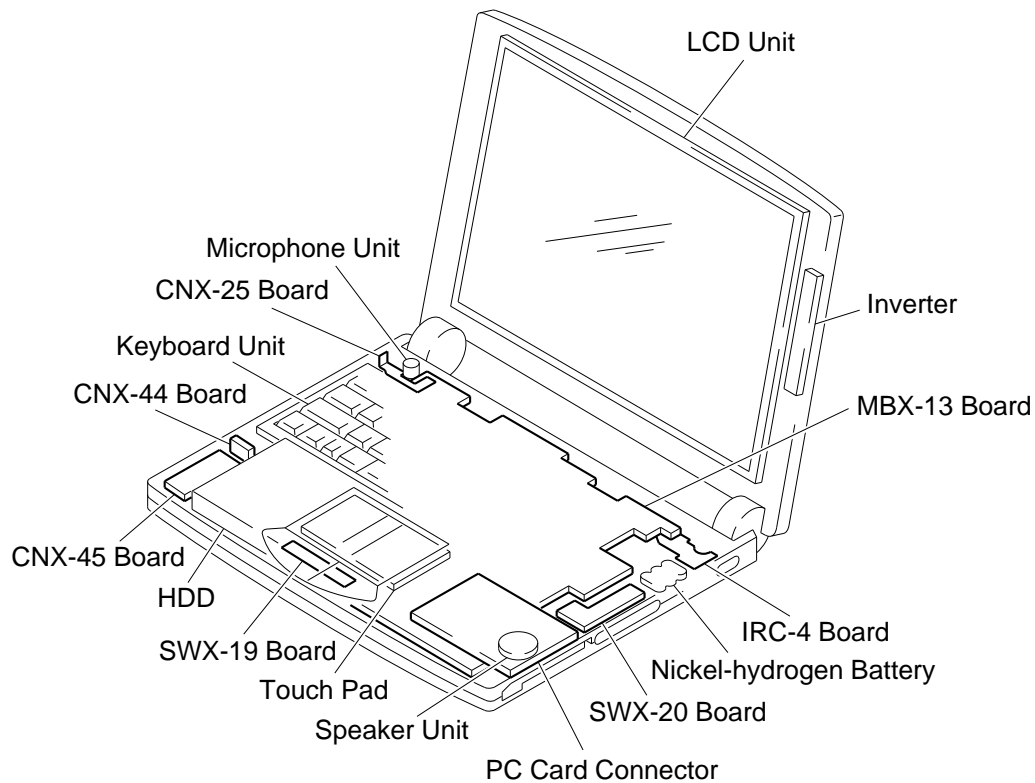

- Note that HDDs (Hard Disc Drives) are easily damaged by shock of impact.

### 1-3. Removal

#### 1. Palm rest housing assembly

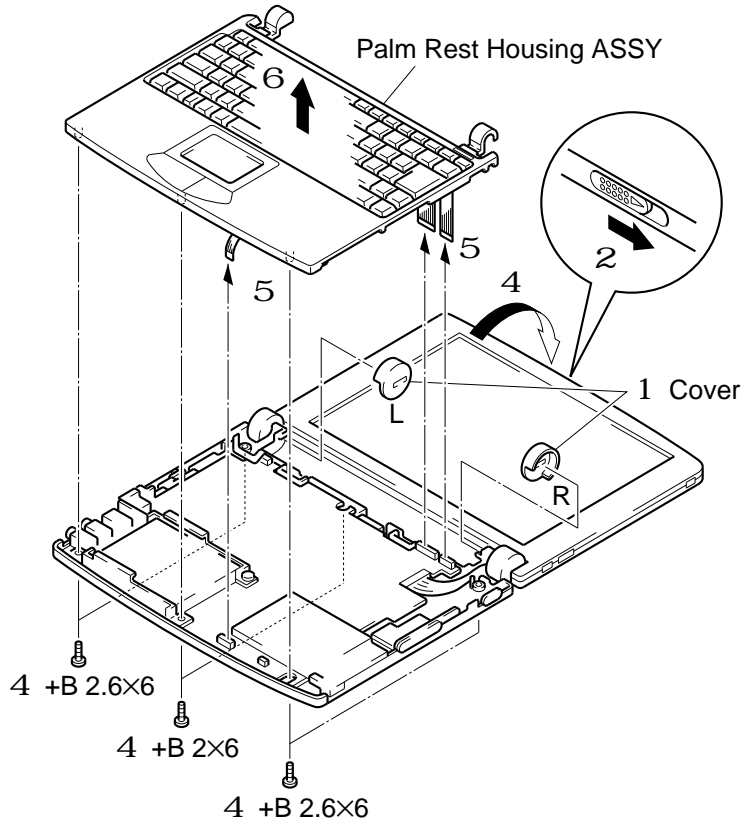

#### 2. Keyboard unit, touch pad, SWX-19 board

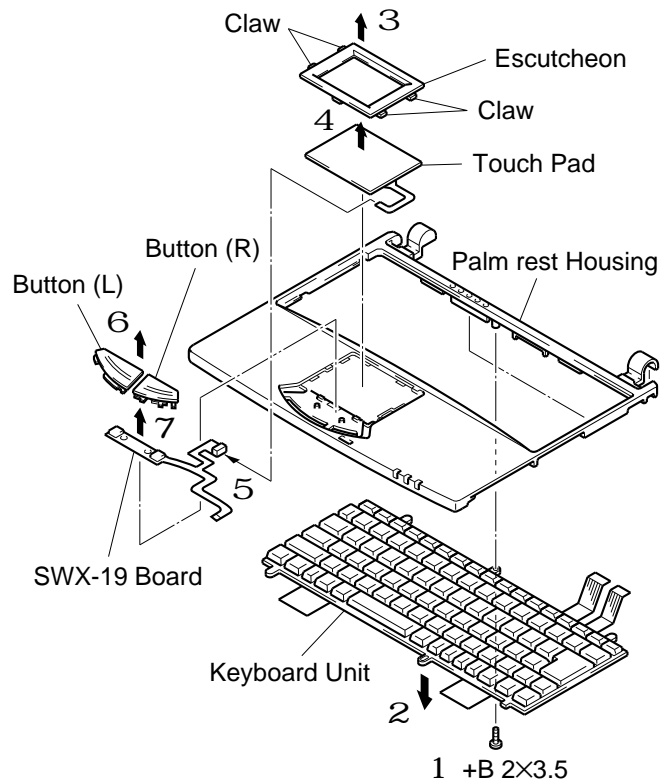

**3. HDD**

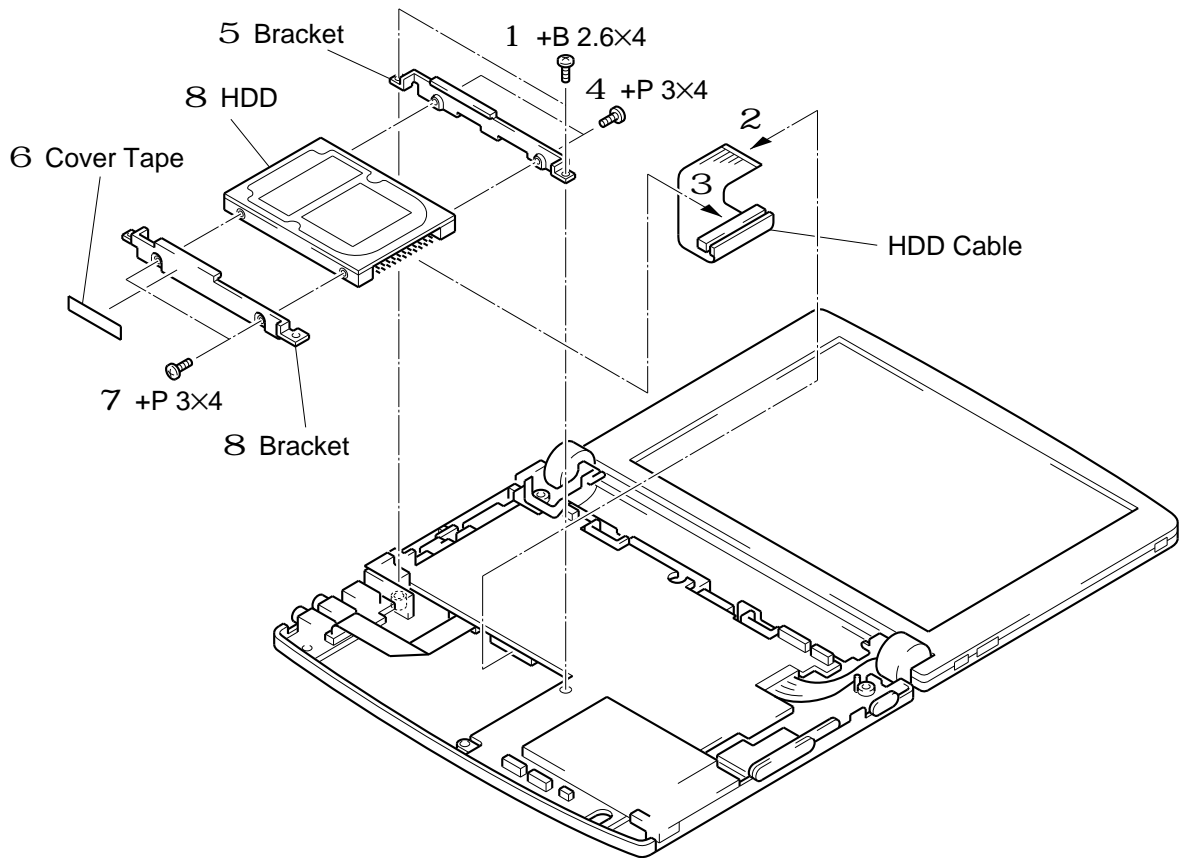

**4. SWX-20 board, IRC-4 board, CNX-44 board, CNX-45 board and CNX-25 board**

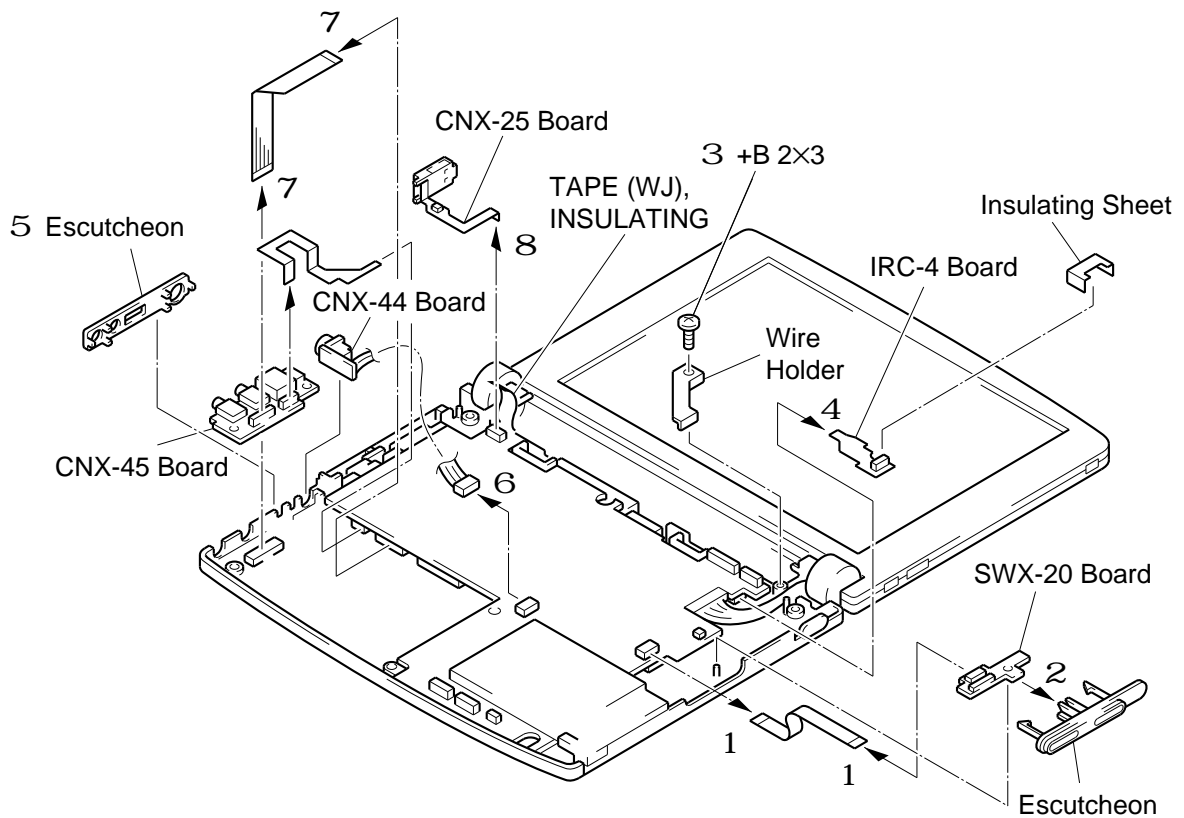

**5. MBX-13 board, speaker unit, and nickel-hydrogen battery**

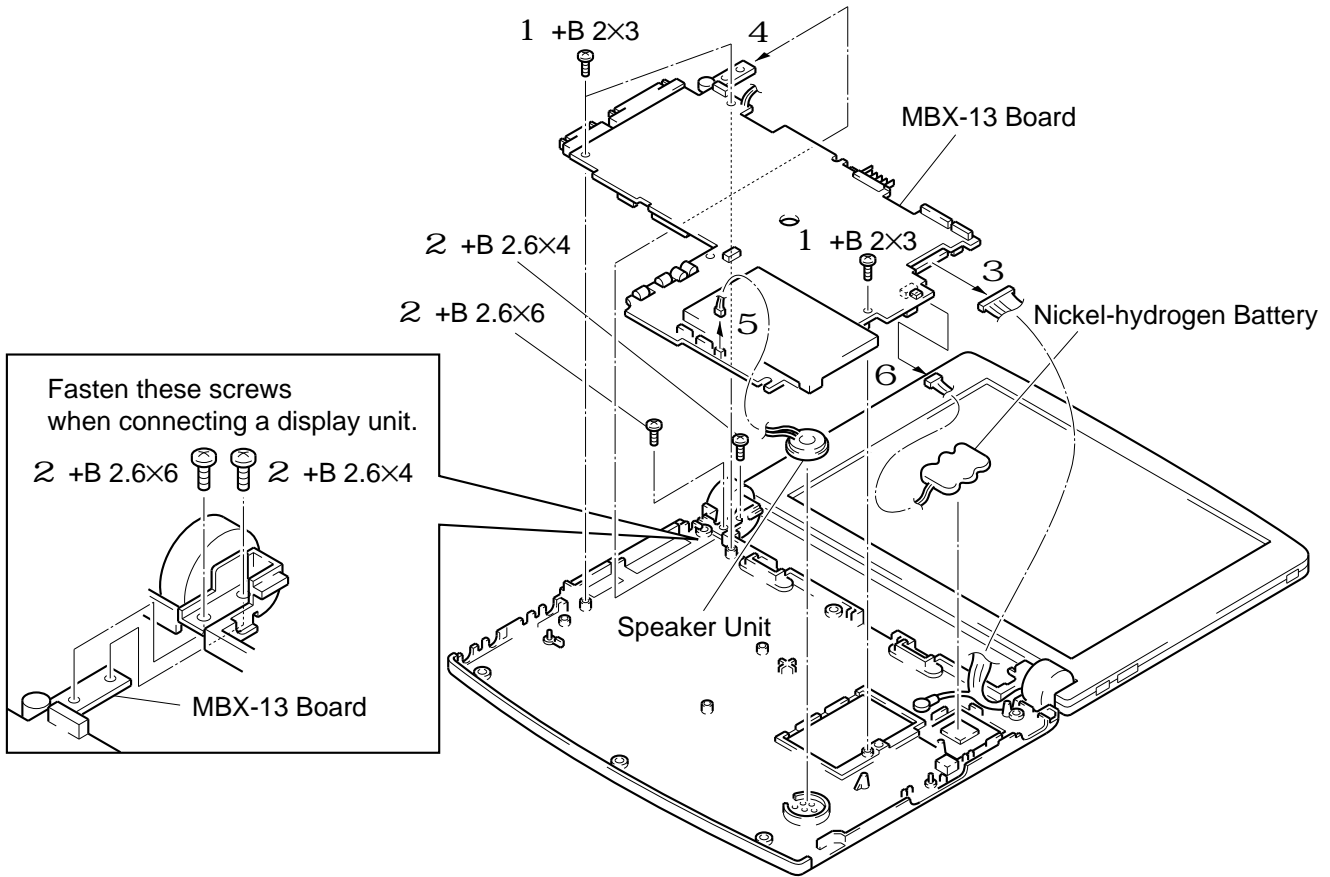

**6. PC card connector, heat pipe, and heat sink**

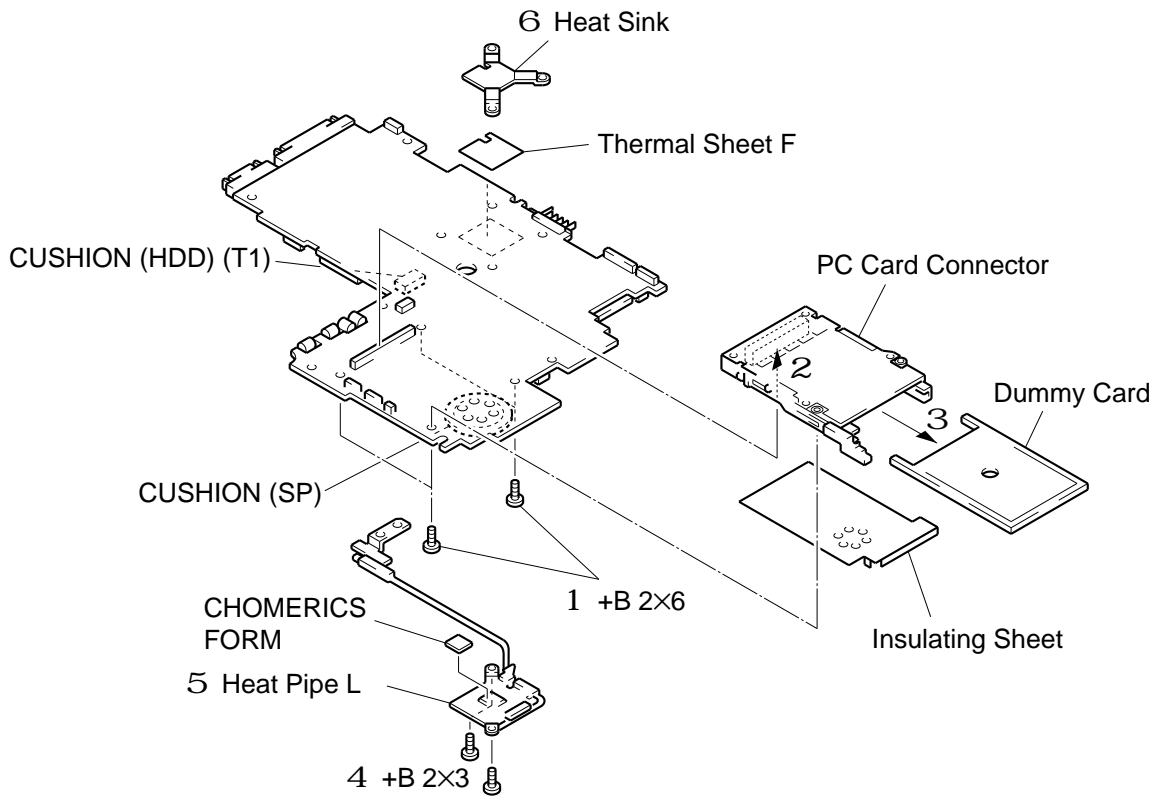



**7. Display assembly**

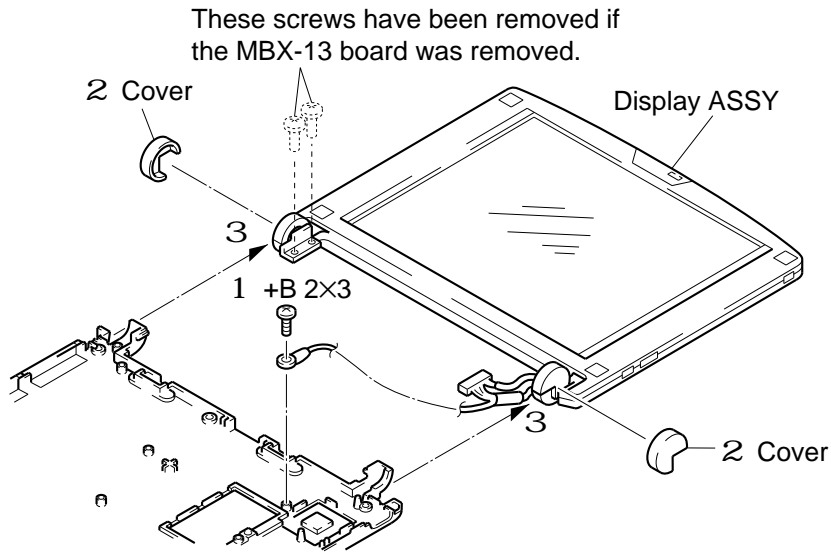

**8. Housing bezel assembly, LCD unit, and inverter**

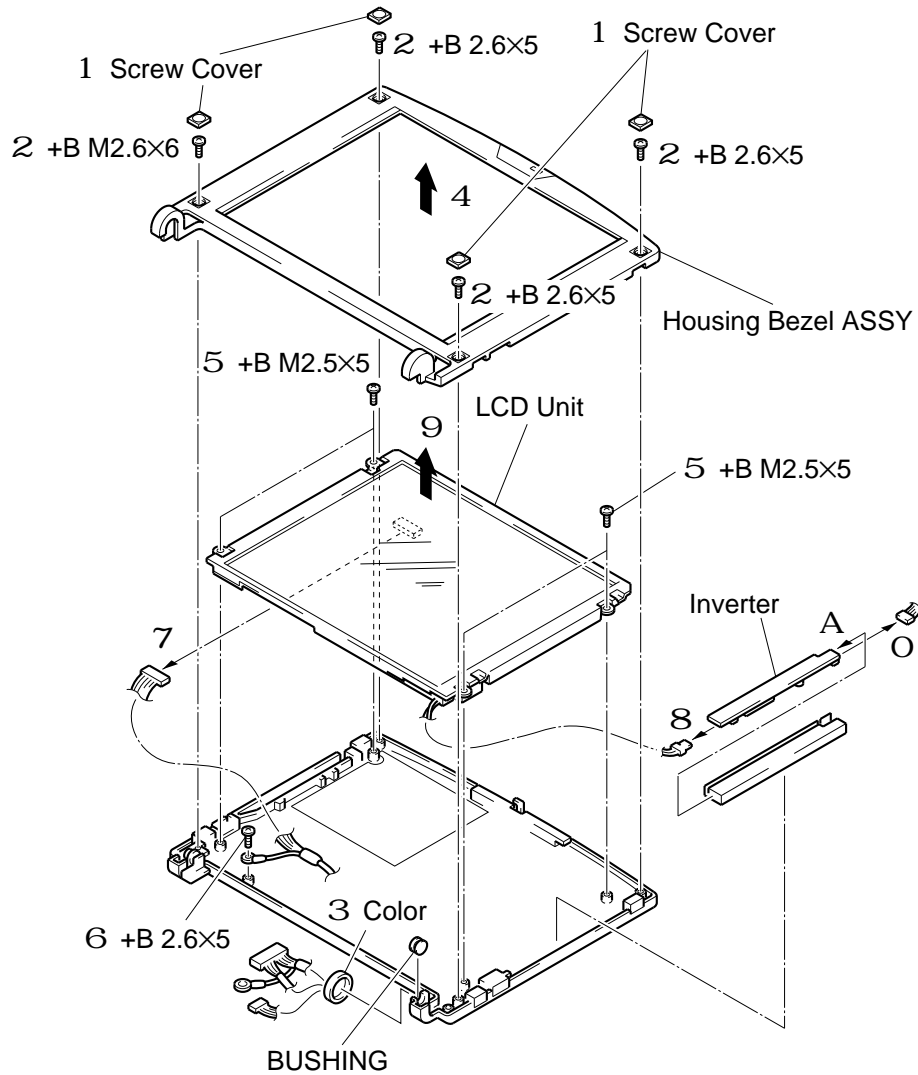



## 2-1. Note

This chapter describes the items to be checked and the self-tests to be performed using the main unit, floppy-disk drive, and CD-ROM drive, Port Replicator.

## 2-2. Necessary Tools

- PCG-505F/FX main unit
- Floppy-disk drive
- CD-ROM drive
- Battery
- AC adaptor
- CD-ROM for self-Diagnostics
- Floppy disk for self-diagnostics (with DOS installed)
- Port Replicator
- Other tools required for the tests

## 2-3. Start-up of the Self-Diagnostics Program

Connect a floppy-disk drive, CD-ROM drive, battery and AC adaptor, Port Replicator to the PCG-505F/FX (hereinafter referred to as the main unit).

Insert a floppy disk for self-diagnostics in the floppy-disk drive and a CD-ROM for self-diagnostics in the CD-ROM drive.

## 2-4. Diagnostics on the Setup Screen

Turn the power of the main unit on, and press F2 with the SONY logo displayed.

The Setup screen appears. Check the BIOS Version, memory capacity, CPU clock, hard-disk capacity, etc.

PhoenixBIOS NoteBIOS 4.0 Setup — Copyright. . .

Main    Advanced    Security    Power    Boot    Exit  
↑            ↑            ↑            ↑            ↑            ↑

The currently selected tag appears in blue with a white background.

- BIOS version  
Tag [MAIN] → Item [BIOS Version] should show the correct BIOS.
- Serial number  
Tag [MAIN] → Item [Serial Number] should be a correct number
- Memory capacity  
Tag [MAIN] → Item [Total Memory] should show sufficient memory (at least 32MB without expansion).
- Video memory  
Tag [MAIN] → Item [Video Memory] should show 1MB.
- Hard disk  
Tag [Advanced] → Press Enter for Item [Primary IDE Adapter (Master)] → Press Enter for Item [Autotype Fixed Disk] will display the hard-disk information under the following items.  
Check whether or not they are correct.

The remaining items are confirmed that they match the default values.

To set to default:

Tag [Exit] → Press Enter for Item [Get Default Values]

Tag [Exit] → Press Enter for Item [Exit (Save Changes)] restarts the unit.

## 2-5. Diagnostics Using the Self-Diagnostics Program

Insert a floppy disk for self-diagnostics in the floppy-disk drive, and a CD-ROM for a self-diagnostics in the CD-ROM drive. When the power of the main unit is turned on, the system starts up from the CD-ROM, and the following screen appears.

```
Diagnosics for Service  Version 1.0.
PCG-505G

(C)1997 Sony Corporation All rights reserved.
Press any key to continue...
```

Press any key, and the Start menu will appear.

```
***** START MENU *****

1:Diagnosics for PCG-505G (Self-Diagnosics)
2:Diagnosics for PCGA-PR5 (Self-Diagnosics)
3:PASSWORD BYPASS          (Password Bypass)
4:QUIT MAIN MENU           (Quit)
```

Move the cursor to the desired item, and press Enter.

- Diagnostics for PCG-505G

When Diagnostics 2 or 3 is selected from the Start menu, the screen shown below will appear.

```
***** Diagnostics for PCG-505G *****

1:Machine Configuration
2:Audio test Group...
3:Battery test...
  :
  :
```

Once you select an item, the self-diagnostics for that item will be performed.

Pressing keys and/or listening to sounds may be required. Follow the instructions on the screen.

\* For details on each item, see “2-6 Test items.”

(Some modifications may be made.)

When the test ends normally:

```
*****
PASS appears.
*****
```

When the test ends abnormally:

```
*****
FAIL appears.
*****
```

- **PASSWORD BYPASS**

If the BIOS is locked with a password and you don't know the password, use this function.  
To use this function, another machine is necessary.

PASSWORD BYPASS is selected from the Start menu, the following screen appears.

```
Password Bypass Program 1.0
(C)1997 Sony Corporation All rights reserved.
Input last 7 digits of Serial number
(If serial xxxxxxxx-ooooooo, input serial number → ooooooo)
Input serial → number
```

Enter the last seven digits of the serial number and a temporary password will appear.

```
Bypassed pass word → zzzzzzz
```

- **QUIT MAIN MENU**

Self-Diagnostics ends.

## **2-6. Test Items**

- **Machine Configuration**

Select which PCG-505-series main unit you are using.

As some test items operate based on this configuration, this should be the first selection made.

- **Audio test Group . . .**

For audio testing.

No details are defined. You listens to the sound and evaluates the results.

- **Battery test . . .**

Test for charging and discharging of the battery.

If the battery is almost fully discharged or overcharged, an error may occur.

- **Check System BIOS Revision . . .**

The BIOS version will appear.

This test always ends in normal status. It's up to you to evaluate the results.

- **FDD test . . .**

Test to find defects in a floppy disk drive.

Be sure to insert a floppy disk without a write-protect tab for self-Diagnostics.

If some defect is detected, the data may be lost. The data should always be backed up.

- **HDD test . . .**

Test for the hard-disk drive.

The recognition test is done in the start-up process with the BIOS.

- Keyboard test . . .  
 Test for keyboard operation.  
 A keyboard appears on a screen. Press the keys one by one. Pressing a function key alone will not be recognized.  
 Press the desired function key with the → key.  
 If a disabled key is found, press the ESC key twice to end the test.
- IrDA test Group . . .  
 Communication test for IrDA.  
 The PCG-505G for communication is required.
- LED test . . .  
 LEDs for the hard-disk drive, NumLock, CapsLock, ScrLck, Information and Battery will light one after another, in that order.  
 After checking all the LEDs, press the y key.
- Memory test Group . . .  
 Tests for memory.  
 The time required for testing depends on the memory capacity.
- Modem AT Command test . . .  
 Test for the modem.  
 This checks for generation of an AT command.  
 No actual call is required.
- System test . . .  
 Tests for items on the mother board.  
 DMA, IRQ, the CPU, etc. are checked.
- Touch Pad test . . .  
 Test for a touch pad.  
 Follow the instructions on the screen. The test proceeds from left-clicking, right-clicking, touching four corners with a pen and, pushing the center with a finger, in that order.  
 To stop the test, press the ESC key.
- USB test . . .  
 Test for an USB port.  
 USB tools are required.
- Video test . . .  
 Test for an LCD display.  
 In the first half, checking that the screen is displayed within a frame and that the palette is normal is performed for your evaluation.  
 The second half is performed as self-diagnostics.
- Programmable power key test . . .  
 Test for a programmable power key.  
 Press it once.
- IEEE 1394 Interface test . . .  
 Communication test of the IEEE 1394.  
 A PCG-505-series unit on which Windows will run is required.

- Parallel loopback test . . .  
Test for a parallel port.  
Connect a loopback tool to the parallel port of the port Replicator, and perform the test.
  
- PS/2 mouse test . . .  
Test for an external mouse.  
Connect a mouse to the mouse connector of the port Replicator.
  
- Serial loopback test . . .  
Test for a serial port.  
Connect a loopback tool to the port Replicator and perform the test.
  
- Modem loopback test . . .  
Perform data transmission and reception between modems.  
Tool modems are required.

## ***2-7. Tests that are not Supported***

- PCMCIA test  
The 16-bit PC-CARD test is replaced with the CD-ROM test.  
Testing a CardBUS, ZV, etc. is not available, because such tests required special hardware.









# CHAPTER 4. FRAME HARNESS DIAGRAM

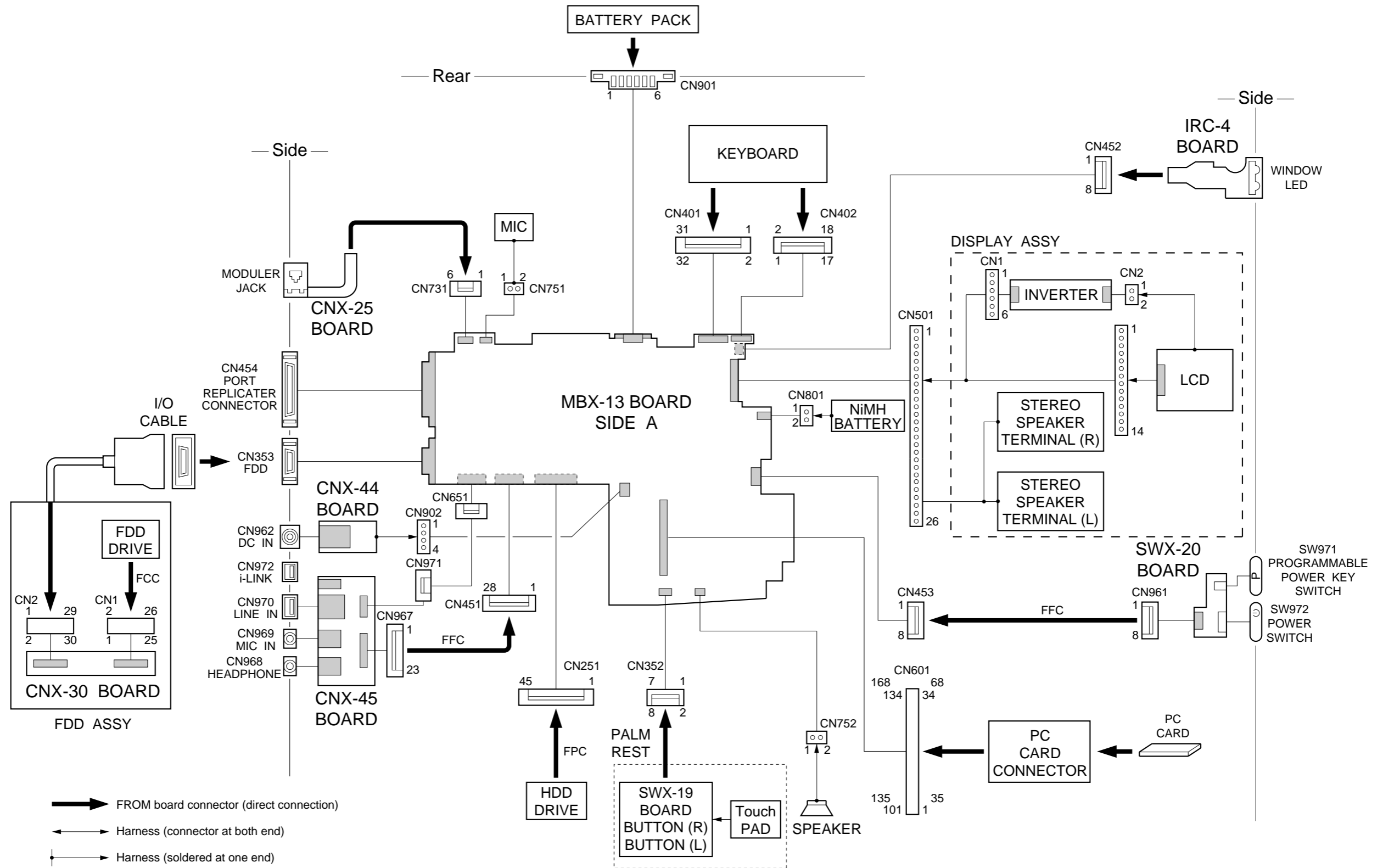



# CHAPTER 5. EXPLODED VIEW AND PARTS LIST

**Note:**

- Parts marked by \* are not normally in stock.
- Any part that has no part number is not available.

The components identified by mark  $\Delta$  or dotted line with mark  $\Delta$  are critical for safety.  
Replace only with part number specified.

## 5-1. Main Unit

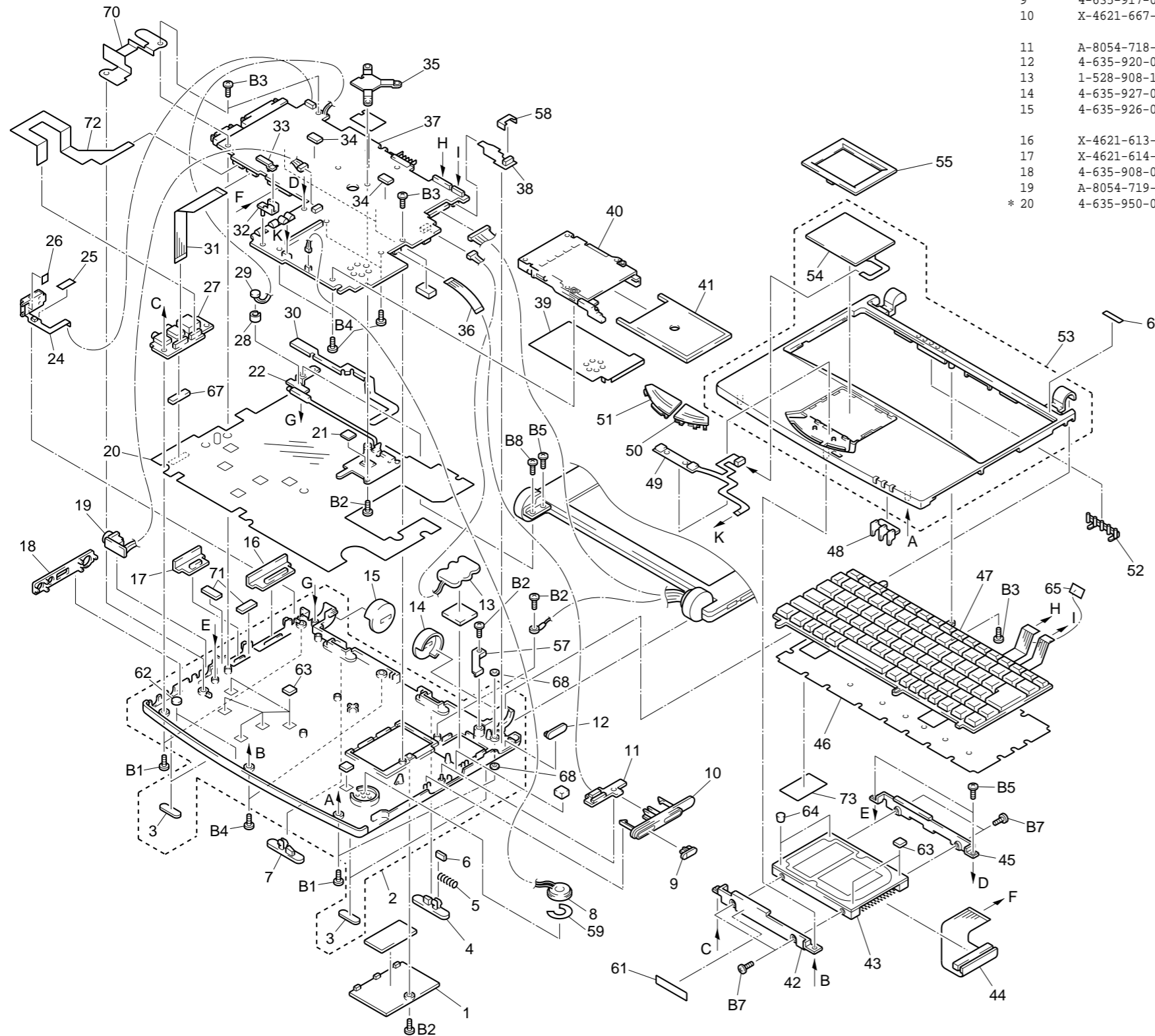

Ref.No.	Part No.	Description
1	4-636-330-01	LID (MEMORY)
2	A-8044-588-A	BOTTOM (1020) ASSY (S), HOUSING
3	4-635-946-01	FOOT
4	4-635-919-03	KNOB (BR)
5	4-635-956-01	SPRING (B), COMPRESSION COIL
6	4-636-934-01	SPACER (SPRING)
7	4-635-918-03	KNOB (BL)
8	1-505-734-11	SPEAKER UNIT
9	4-635-917-02	KONB (POWER)
10	X-4621-667-1	ESCUTCHEON (BUTTON) ASSY
11	A-8054-718-A	SWX-20, 1020, ASSY (S)
12	4-635-920-01	WINDOW
13	1-528-908-11	BATTERY, NICKEL HYDROGEN
14	4-635-927-01	COVER (RL)
15	4-635-926-01	COVER (LR)
16	X-4621-613-1	LID (FDD) ASSY
17	X-4621-614-1	LID (REPLICATOR) ASSY
18	4-635-908-01	ESCUTCHEON (JACK)
19	A-8054-719-A	CNX-44, 1020, ASSY (S)
* 20	4-635-950-02	INSULATING SHEET (BOTTOM)

Ref.No.	Part No.	Description
* 21	4-632-530-01	CHOMERICS FOAM
* 22	4-683-229-01	PIPE (L), HEAT
24	1-783-159-11	FPC (CUX-25)
25	4-636-345-01	TAPE (WJ), INSULATING
26	4-635-952-01	INSULATING SHEET (WJ)
27	A-8054-720-A	CNX-45, 1020, ASSY (S)
28	4-635-923-01	HOLDER (MICROPHONE)
29	1-542-331-11	MICROPHONE UNIT
30	4-638-232-01	INSULATING SHEET (PIPE L)
31	1-783-098-11	CABLE, FLEXIBLE FLAT (24 CORE)
32	4-635-922-01	HOLDER (SW)
33	4-635-949-01	PLATE (SW)
34	4-636-344-01	CUSHION (KB)
* 35	4-636-329-01	HEAT SINK (VIA)
36	1-783-815-11	FPC (8 CORE)
37	A-8045-021-A	(505F)...MBX-13, 1020U, 233 ASSY (S)
	A-8045-022-A	(505FX)...MBX-13, 1020U, 266 ASSY (S)
38	1-783-161-11	FPC (IRC-4)
39	4-635-955-11	INSULATING SHEET (PCMCIA)
40	1-779-808-11	CONNECTOR, PC CARD
41	4-627-811-21	CARD, DUMMY
* 42	4-635-930-01	BRACKET (HDDF)
43	A-8054-876-A	4.3" HDD ASSY (S)
44	1-782-617-11	FPC (HDD CABLE)
* 45	4-635-931-01	BRACKET (HDDR)
46	4-635-951-01	INSULATING SHEET (KEY BOARD)
47	A-8054-714-A	KEY BOARD (U) ASSY (S)
48	4-635-914-02	LENS (F)
49	1-783-590-11	FPC (SWX-19)
50	4-635-913-03	BUTTON (R)
51	4-635-912-04	BUTTON (L)
52	4-635-915-01	LENS (R)
53	A-8044-589-A	REST (1020) ASSY(S), PARM
54	1-759-461-11	PAD, TOUCH
55	4-635-910-05	ESCUTCHEON (PAD)
57	4-636-932-01	HOLDER (WIRE)
58	4-637-148-02	INSULATED PLATE (IRDA)
59	4-637-074-01	SPACER (SP)
60	4-637-454-21	LABEL ID
61	4-637-411-01	TAPE (BLIND)
62	4-636-551-01	CUSHION (HDD) (T0.5)
63	4-626-552-01	CUSHION (HDD) (T1)
64	4-636-553-01	CUSHION (HDD) (T2)
65	3-839-640-00	CUSHION
67	4-637-139-01	GASKET (4X2)
68	4-637-147-01	SPACER (DIA. 5.7)
70	4-638-221-01	PLATE, CONDUCTOR
71	4-638-234-01	GASKET (CONNECTOR)
72	1-670-718-11	FPC (CNX-48)
73	4-637-075-01	TAPE (KEY BOARD)
B1	7-621-770-67	+B 2.6X6
B2	7-621-772-08	+B 2X3
B3	7-621-772-18	+B 2X4
B4	7-621-772-38	+B 2X6
B5	7-621-773-86	+B 2.6X4
B6	7-621-775-20	+B 2.6X5
B7	7-682-145-01	+P 3X4
B8	7-621-259-45	+P 2.6X6

## 5-2. Display Unit

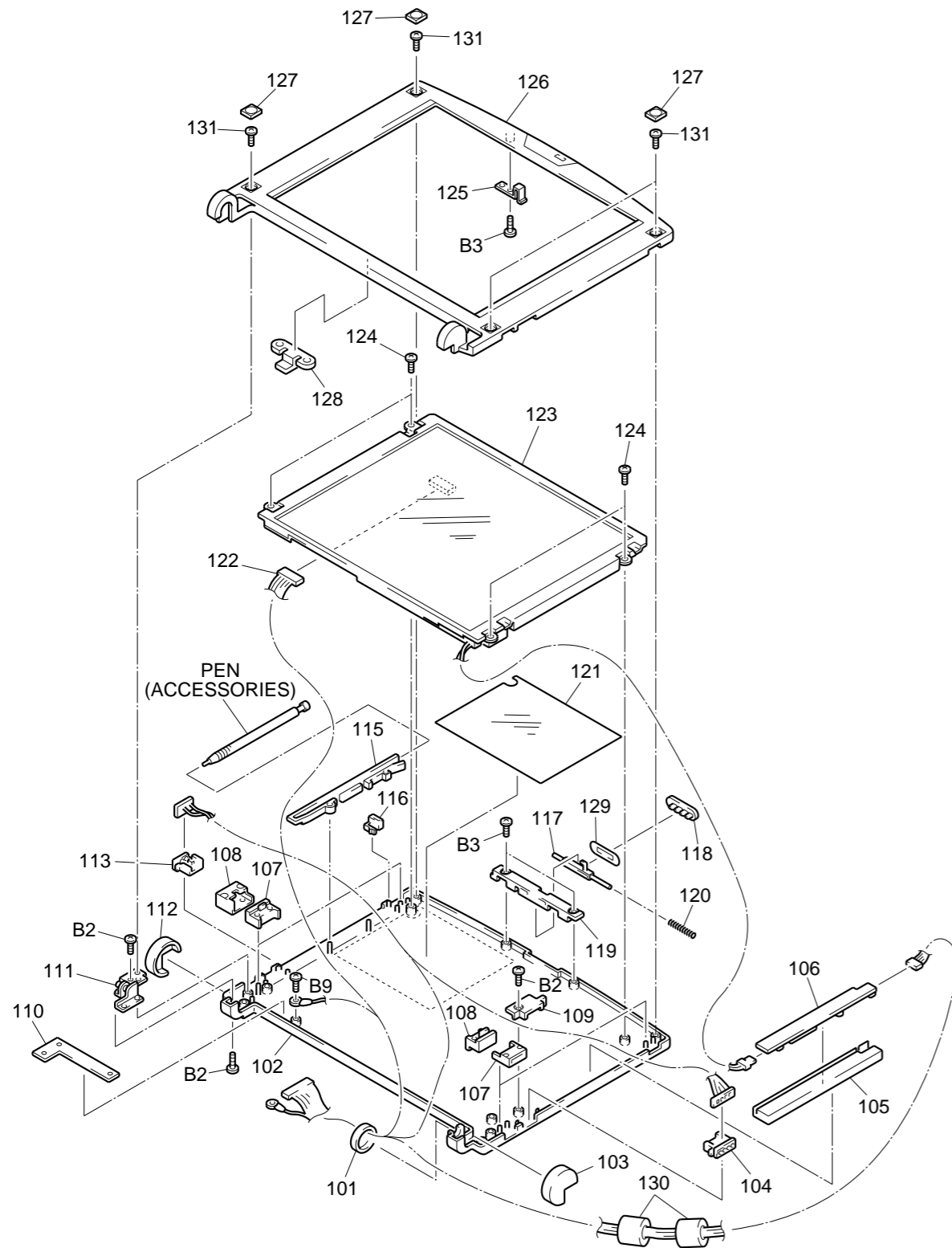

Ref.No.	Part No.	Description
* 101	4-635-947-01	COLOR
102	X-4621-652-1	HOUSING (DISPLAY) ASSY
103	4-635-929-01	COVER (RR)
104	4-636-332-01	HOLDER (RIGHT), PC BOARD
105	4-635-944-01	INSULATOR (1VT)
106	1-475-400-11	INVERTER (LCD)
107	4-636-339-01	BLIND (SNAP RETAINER), HOLE
108	4-636-335-01	SNAP RETAINER
109	4-636-334-01	CLAMP
* 110	4-636-338-01	PLATE, HEAT TRANSFER
111	X-4621-545-1	TILT UNIT ASSY
112	4-635-928-01	COVER (LL)
113	4-636-333-01	HOLDER (LEFT), PC BOARD
115	4-635-937-01	HOLDER (PEN)
116	4-635-938-01	LOCK (PEN)
117	4-635-934-01	LEVER (LATCH)
118	4-635-932-01	KNOB (LATCH)
119	4-635-935-01	HOLDER (LATCH)
120	2-300-616-01	SPRING, COMPRESSION
121	4-636-558-01	INSULATOR (LCD)
122	1-958-912-11	HARNESS (LCD SPEAKER)
123	A-8054-418-A	10.4" LCD ASSY (S)
124	4-636-559-01	SCREW (+B M2.5X4)
125	4-636-331-01	CLAW, JOINT
126	X-4621-669-1	HOUSING (BEZEL) ASSY
127	4-635-939-01	COVER (SCREW)
128	4-636-945-01	CLAN (B), JOINT
129	4-637-460-01	SPACER
130	4-637-232-01	TUBE
131	4-636-560-01	SCREW (+B M2.6X5.5)
B2	7-621-772-18	+B 2X4
B9	7-621-772-08	+B 2X3

### 5-3. FDD Assembly

Ref.No.	Part No.	Description
201	4-636-397-01	FOOT (FDD)
202	3-719-381-31	SCREW (M2X3)
203	4-636-391-04	CASE (LOWER)
204	4-636-394-01	GUIDE, LIGHT
205	A-8054-413-A	CNX-30 MOUNTED PWB
206	1-783-043-11	CABLE, I/O (26P)
207	3-948-339-01	SCREW, TAPPING
* 208	4-636-395-01	PLATE, SHIELD
* 209	4-636-396-01	INSULATING SHEET
210	A-8054-426-A	3.5" FDD ASSY (S)
211	4-636-398-01	CUSHION
212	1-782-868-11	FFC (FDD)
213	4-636-390-04	CASE (UPPER)
214	4-636-399-01	RUBBER, RETAINER
215	4-636-392-01	ESCUTCHEON (CONNECTOR)
* 216	4-636-393-01	BRACKET
217	3-719-381-21	SCREW (M2X6)

### ACCESSORIES & PACKING MATERIALS

Ref.No.	Part No.	Description
△	A-8054-713-A	AC ADAPTOR 1020 U ASSY (S)
*	1-777-926-31	CORD, CONNECTION
*	A-8044-383-A	FDD (505) ASSY
	A-8054-768-A	PACK (S) ASSY(S), BATTERY
	4-635-936-01	PEN
	3-865-464-11	MANUAL (MAIN), INSTRUCTION
	A-8044-650-A	PORT REPLICATOR (PR5 ASSY)

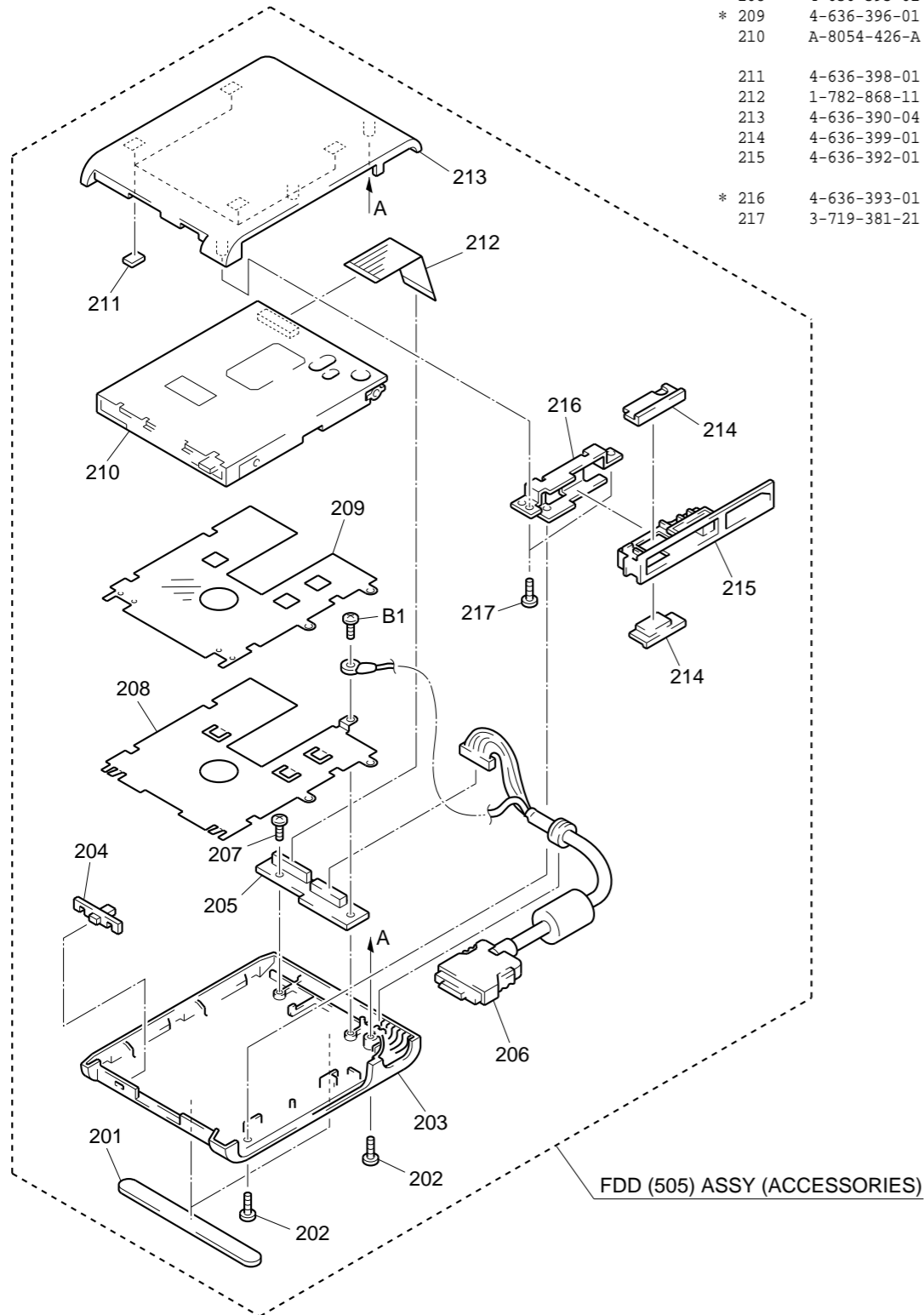





# QUICK MEMO

(1/1)

No. FIT- **M2001\_013K**

■ J ■ UC ■ E □ I

## The object of information

Technical  Parts  Other information

Date : 2001.3.19

From : PNC Planning & Control Dept.  
[SODP]

## The relation document to the plan of

T/N  Service manual  Others  No publication

Tel : +81 3 5795 6931

## [Model/Series]

### PCG-505 Series

VAIO Notebook Computer SERVICE MANUAL

## [Subject]

### ADDITION

## [Contents]

### Addition (of part)

Model (Page)	Ref.No.	Part No.	Description
J 505, 505X/505EX, 505G/GX (505G/GX ADD-1), 505RX/RS/R, 505SX/S (505SX/4G), 505V, 505V/ABX, 505V/CBX, 505V/CBP	80	4-638-224-01	SHEET (F) THERMAL
UC 505F/FX, 505TX/TS, 505TR 505G/GX			
E 505E, 505G			

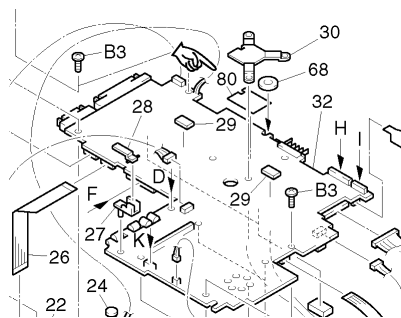

\* Please make these changes on the list of repair parts as well until revised version published.

## [Applicable Models]

J	: PCG-505	(9-974-467-01)
	PCG-505X/505EX	(9-974-473-01)
	PCG-505G/GX (505G/GX ADD-1)	(9-974-481-01)
	PCG-505RX/RS/R	(9-974-492-01)
	PCG-505SX/S (505SX/4G)	(9-928-301-01)
	PCG-505V	(9-928-325-01)
	PCG-505V/ABX	(9-928-326-01)
	PCG-505V/CBX	(9-928-348-01)
	PCG-505V/CBP	(9-872-014-01)
UC	: PCG-505F/FX	(9-974-491-11)
	PCG-505TX/TS	(9-928-301-11)
	PCG-505TR	(9-928-328-01)
	PCG-505G/GX	(9-974-481-11)
E	: PCG-505E	(9-928-301-31)
	PCG-505G	(9-974-481-31)

< For Japanese staff > Please look at information in Japanese by visiting at our web site.