

SVZ131 Series

SERVICE MANUAL

Ver 1-2011E

Revision History

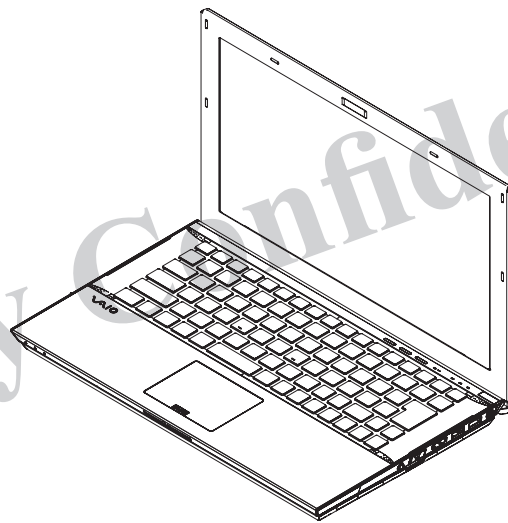

- Design and specifications are subject to change without notice.
- 本機の仕様および外観は、改良のため予告なく変更することがありますが、ご了承ください。

PERSONAL COMPUTER

SONY[®]

9-890-896-01

Information in this document is subject to change without notice.

Sony, VAIO and CLIE are trademarks or registered trademarks of Sony. Microsoft, Windows, Windows Media, Outlook, Bookshelf and other Microsoft products are trademarks or registered trademarks of Microsoft Corporation in the United States and other countries. The word Bluetooth and the Bluetooth logo are trademarks of Bluetooth SIG, Inc. AMD, the AMD logo, other AMD product names and combinations thereof are trademarks of Advanced Micro Devices, Inc. Intel Inside logo, Pentium, Celeron and Core are trademarks or registered trademarks of Intel Corporation. Transmeta, the Transmeta logo, Crusoe Processor, the Crusoe logo and combinations thereof are trademarks of Transmeta Corporation in the USA and other countries. Graffiti, Hot-Sync, PalmModem, and Palm OS are registered trademarks, and the Hotsync logo and Palm are trademarks of Palm, Inc. or its subsidiaries. (M) and Motorola are trademarks of Motorola, Inc. Other Motorola products and services with (R) mark like Dragonball are the trademarks of Motorola, Inc.

All other names of systems, products and services in this manual are trademarks or registered trademarks of their respective owners. In this manual, the (TM) or (R) mark are not specified.

The components identified by mark  contain confidential information. Strictly follow the instructions whenever the components are repaired and/or replaced.

Caution Markings for Lithium/Ion Battery - The following or similar texts shall be provided on battery pack of equipment or in both the operating and the service instructions.

CAUTION: Danger of explosion if battery is incorrectly replaced. Replace only with the same or equivalent type recommended by the manufacturer. Discard used batteries according to the manufacturer's instructions.

CAUTION: The battery pack used in this device may present a fire or chemical burn hazard if mis-treated. Do not disassemble, heat above 60°C (140°F) or incinerate. Dispose of used battery promptly. Keep away from children.

CAUTION: Changing the back up battery.
• Overcharging, short circuiting, reverse charging, mutilation or incineration of the cells must be avoided to prevent one or more of the following occurrences; release of toxic materials, release of hydrogen and/or oxygen gas, rise in surface temperature.
• If a cell has leaked or vented, it should be replaced immediately while avoiding to touch it without any protection.

Service and Inspection Precautions

1. Obey precautionary markings and instructions

Labels and stamps on the cabinet, chassis, and components identify areas requiring special precautions. Be sure to observe these precautions, as well as all precautions listed in the operating manual and other associated documents.

2. Use designated parts only

The set's components possess important safety characteristics, such as noncombustibility and the ability to tolerate large voltages. Be sure that replacement parts possess the same safety characteristics as the originals. Also remember that the  mark, which appears in circuit diagrams and parts lists, denotes components that have particularly important safety functions; be extra sure to use only the designated components.

3. Always follow the original design when mounting parts and routing wires

The original layout includes various safety features, such as inclusion of insulating materials (tubes and tape) and the mounting of parts above the printer board. In addition, internal wiring has been routed and clamped so as to keep it away from hot or high-voltage parts. When mounting parts or routing wires, therefore, be sure to duplicate the original layout.

4. Inspect after completing service

After servicing, inspect to make sure that all screws, components, and wiring have been returned to their original condition. Also check the area around the repair location to ensure that repair work has caused no damage, and confirm safety.

5. When replacing chip components...

Never reuse components. Also remember that the negative side of tantalum capacitors is easily damaged by heat.

6. When handling flexible print boards...

- The temperature of the soldering-iron tip should be about 270°C.
- Do not apply the tip more than three times to the same pattern.
- Handle patterns with care; never apply force.

Caution: Remember that hard disk drives are easily damaged by vibration. Always handle with care.

ATTENTION AU COMPOSANT AYANT RAPPORT À LA SÉCURITÉ!
LES COMPOSANTS IDENTIFIÉS PAR UNE MARQUE  SUR LES DIAGRAMMES SCHÉMATIQUES ET LA LISTE DES PIÈCES SONT CRITIQUES POUR LA SÉCURITÉ DE FONCTIONNEMENT. NE REMPLACER CES COMPOSANTS QUE PAR DES PIÈCES SONY DONT LES NUMÉROS SONT DONNÉS DANS CE MANUEL OU DANS LES SUPPLÉMENTS PUBLIÉS PAR SONY.

Sony Confidential

SVZ131 Series (9-890-896-XX)

TABLE OF CONTENTS

<u>Section</u>	<u>Title</u>	<u>Page</u>
CHAPTER 1. BLOCK DIAGRAM	1-1
		(to 1-1)
CHAPTER 2. FRAME HARNESS DIAGRAM	2-1
		(to 2-1)
CHAPTER 3. EXPLODED VIEWS		
Main Section		
MS-1	3-2
LCD		
L-1	3-3
Accessories		
A-1	3-4
Accessories (DOCKING STATION)		
A-2	3-5
Accessories (STAND)		
A-3	3-6
		(to 3-6)
CHAPTER 4. OTHERS		
4-1. Note for WAN Board Replacement	4-1
4-2. Note for WiMAX Board Replacement	4-2
		(to 4-2)

• History of the changes is shown as the "Revision History" at the end of this data.

• 変更履歴は、「Revision History」として、本データ末に記載してあります。

CHAPTER 1. BLOCK DIAGRAM

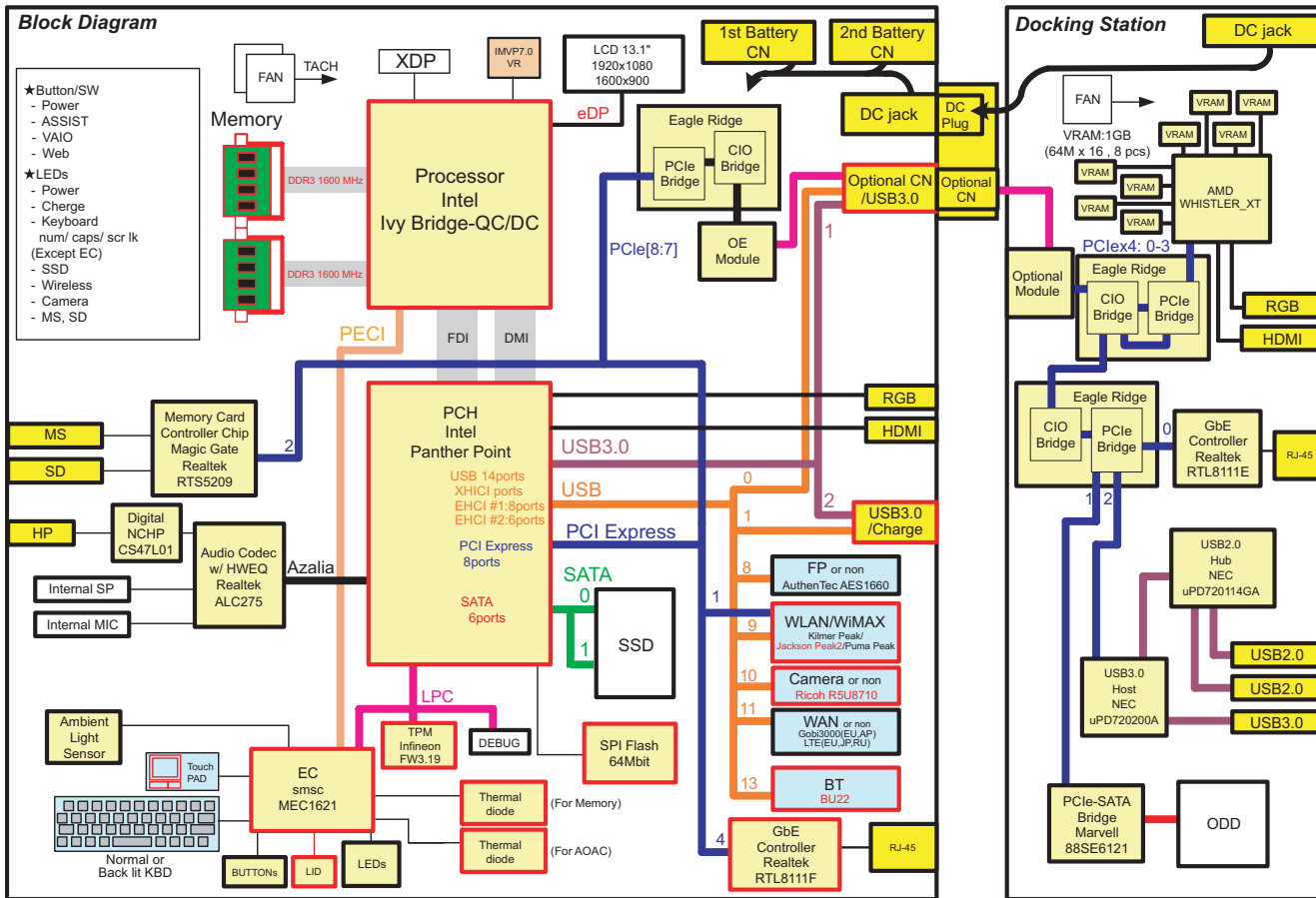

Sony Confidential

SVZ131 Series (9-890-896-XX)

CHAPTER 2. FRAME HARNESS DIAGRAM

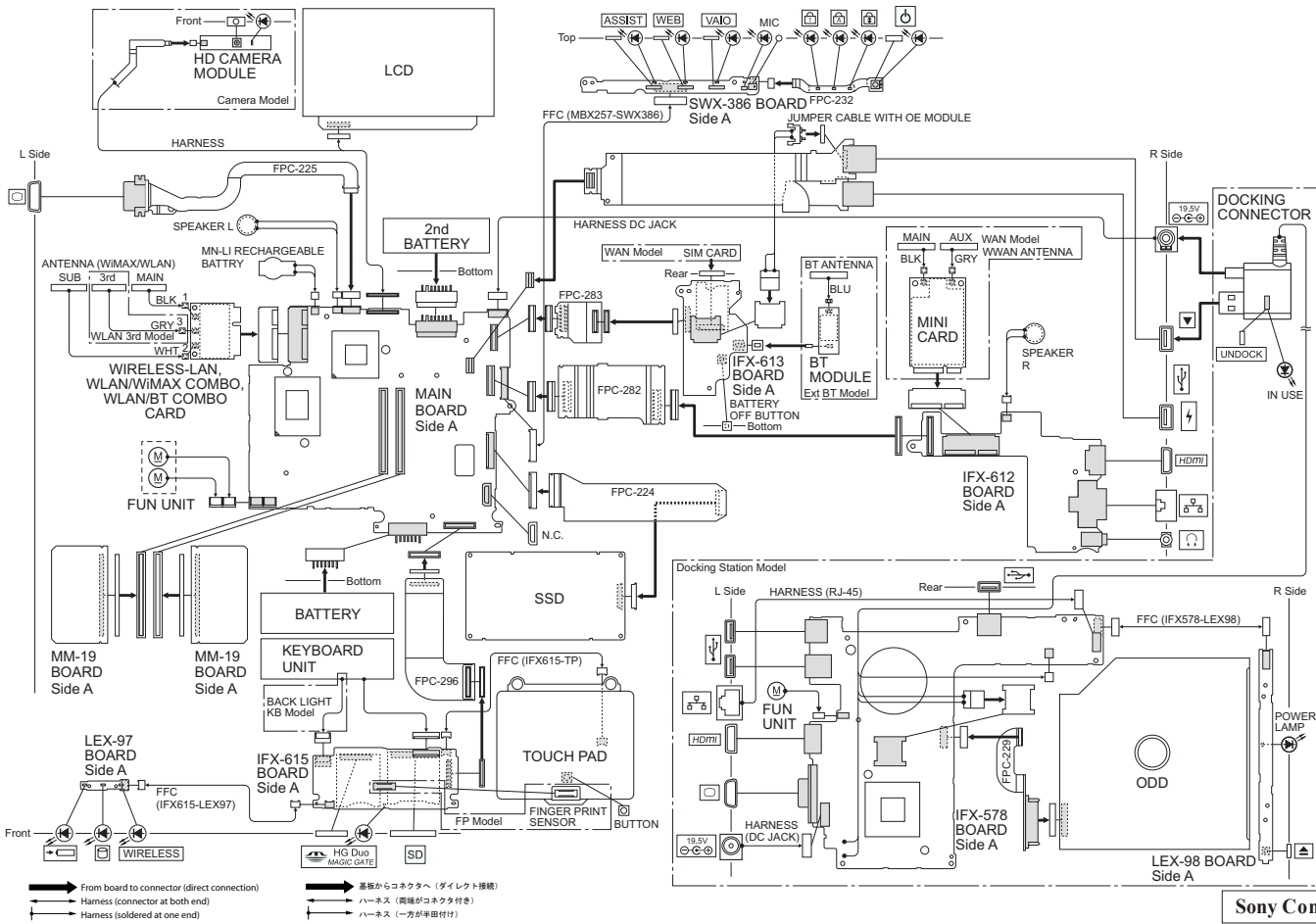

2-1
(END)

Sony Confidential

SVZ131 Series (9-890-896-XX)

CHAPTER 3. EXPLODED VIEWS

Section	Page
Main Section	
MS-1	3-2
LCD	
L-1	3-3
Accessories	
A-1	3-4
Accessories (DOCKING STATION)	
A-2	3-5
Accessories (STAND)	
A-3	3-6

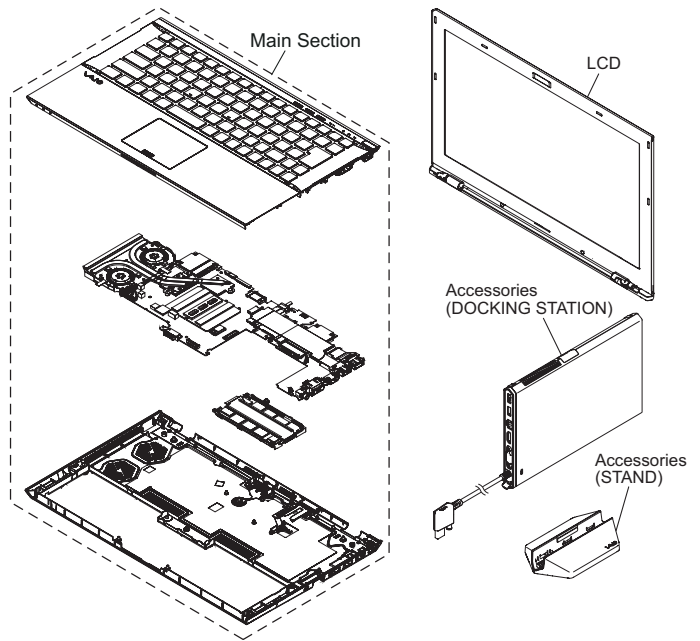

L-1. LCD

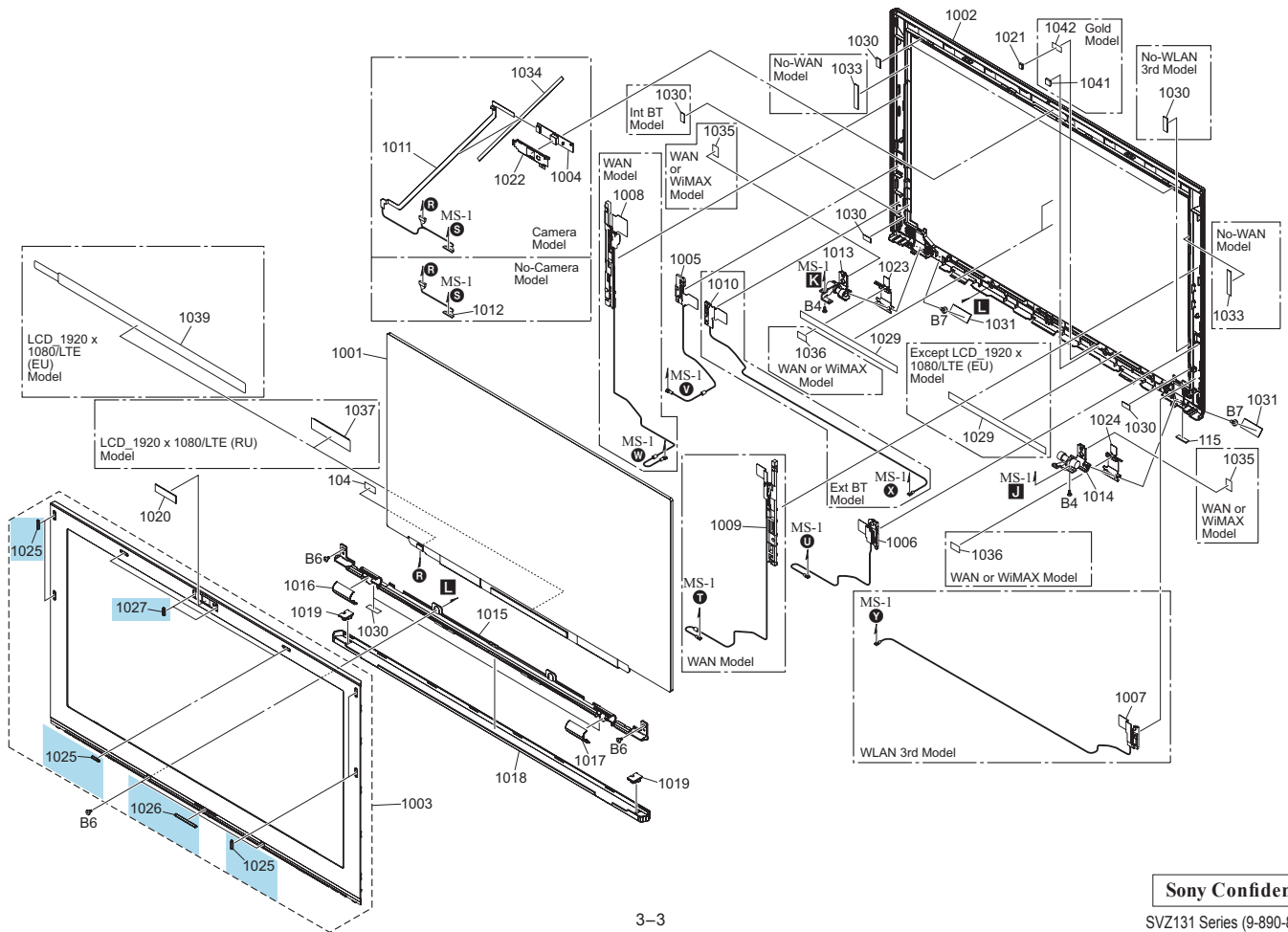

A-1. Accessories

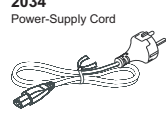
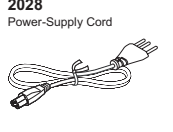
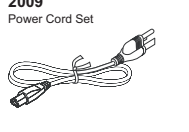
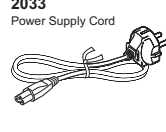
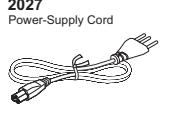
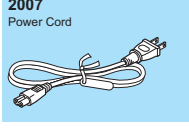
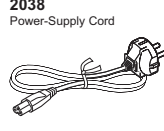
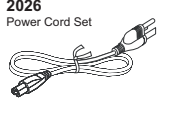
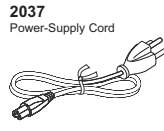
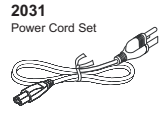
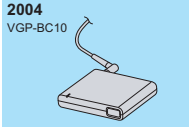
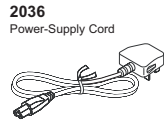
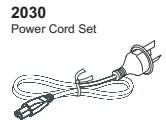
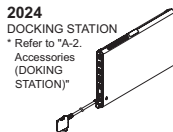
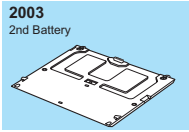
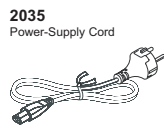
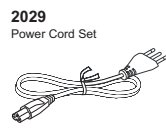
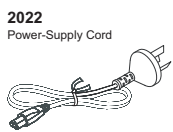
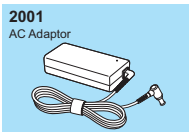

For DOCKING STATION

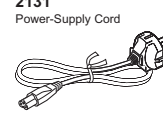
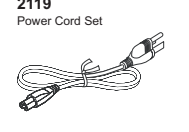
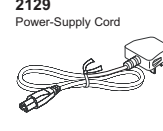
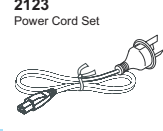
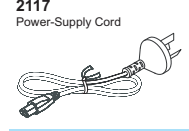
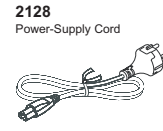
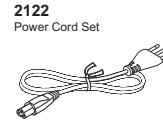
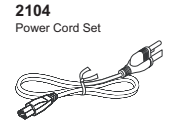
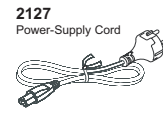
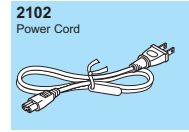
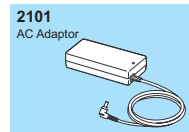

A-2. Accessories (DOCKING STATION)

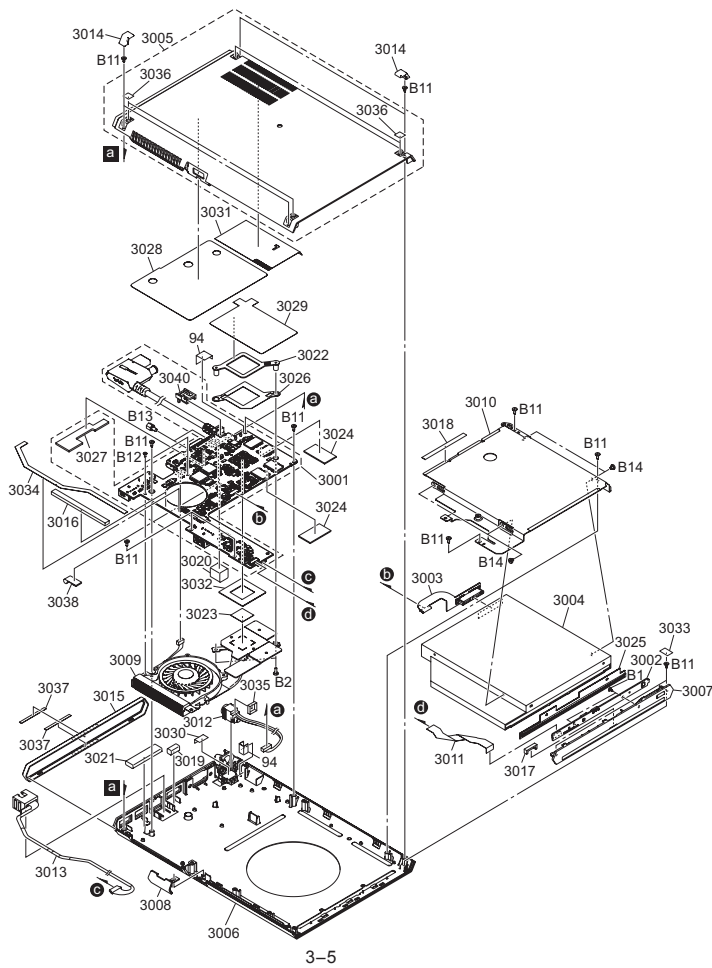

3-5

Sony Confidential

SVZ131 Series (9-890-896-XX)

A-3. Accessories (STAND)

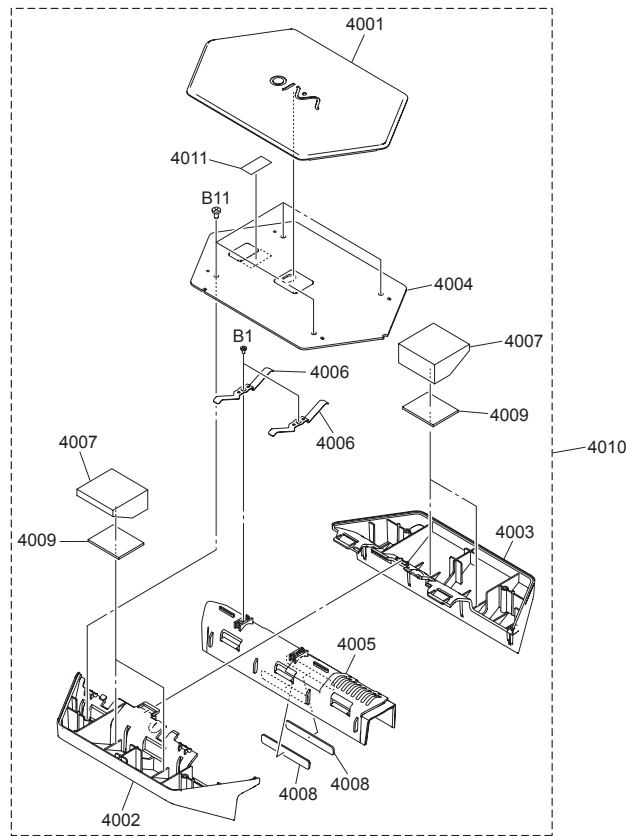

3-6
(END)

Sony Confidential
SVZ131 Series (9-890-896-XX)

CHAPTER 4. OTHERS

4-1. Note for WAN Board Replacement

4-1. WAN 基板交換時の注意

When replacing the WAN Board (Ref. 23 A-1887-442--A, A-1887-667--A), change the barcode label on the bottom.
WAN 基板 (Ref. 23 A-1887-442--A, A-1887-667--A) を交換した際には、ボトムのパールコードラベルの貼り替え作業を行ってください。

- ① Peel off the barcode label which is attached to the bottom. (Refer to the figure below.)
- ① ボトムに貼られているパールコードラベルをはがします。(下図参照)

Ref. 23
EU Model
A-1887-442-A GOBI3000 US-EU-AP MINI CARD 13 (S)
A-1887-667-A LTE EU WWAN MINI CARD-12 (S)

AP Model
A-1887-442-A GOBI3000 US-EU-AP MINI CARD 13 (S)

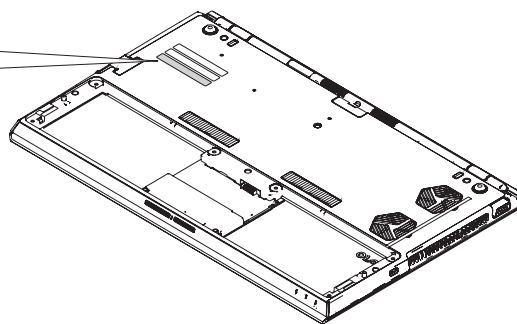

- ② Attach the barcode label which is included with the WAN Board to the position where you peeled off the label in the step ①.
- ② WAN 基板に同梱されているパールコードラベルを①ではがした位置に貼ってください。

Sony Confidential

SVZ131 Series (9-890-896-XX)

4-2. Note for WiMAX Board Replacement

4-2. WiMAX 基板交換時の注意

When replacing the WiMAX Board (Ref. 22 A-1769-477-A) change the barcode label on the bottom.

WiMAX基板 (Ref. 22 A-1769-477-A)を交換した際には、ボトムのパールコードラベルの貼り替え作業を行ってください。

- ① Peel off the barcode label which is attached to the bottom. (Refer to the figure below.)
- ① ボトムに貼られているパールコードラベルをはがします。(下図参照)

Ref. 22
A-1769-477-A CARD, WLAN/WiMAX COMBO-11 L (S)

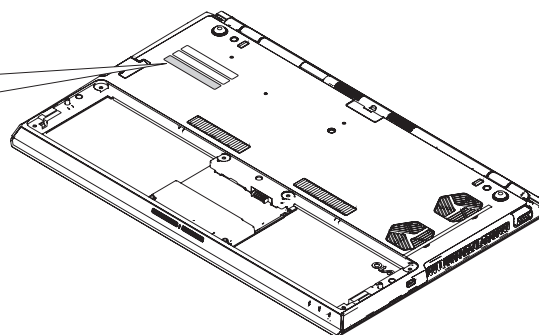

- ② Attach the barcode label which is included with the WiMAX Board to the position where you peeled off the label in the step ①.
- ② WiMAX 基板に同梱されているパールコードラベルを①ではがした位置に貼ってください。



SVZ131 Series

This manual and the constituent data may not be replicated, copied nor reprinted in whole or in part without prior written authorization of Sony Corporation.

本マニュアルの一部、または全部について、無断でデータの複製、複写、転載することを禁じます。

9-890-896-01

Sony Corporation

- 14 -

English / Japanese
2012E2700-1
© 2012 Sony Corporation
Published by Sony Corporation VAIO & Mobile Business Group CS & Quality Div. VAIO Global CS Dept.

Revision History

Suffix	Ver.	Date	Contents	QM No.
-01	Ver. 1	2012.05.14	First Edition	-
<Remarks>				

526

[Sony Confidential]
SVZ131 Series (9-890-896-XX)