

VAIO
no more bounds



Intel® Centrino® Mobile Technology

Platinum sophistication wherever you go



VAIO TX
VGN-TX37GP/W

like.no.other

SONY

Specifications

Model	VGN-TX37GP/W
Platform	Intel® Centrino® Mobile Technology • Intel® Core™ Solo Processor U1400 (1.20GHz)*1 • Intel® PRO/Wireless 3945ABG Network Connection • Intel® 945GMS Express Chipset
Operating System	Microsoft® Windows® XP Professional with Service Pack 2 (English version) Multilingual User Interface (pre-installed Traditional Chinese)
Processor System Bus	533MHz
Memory Bus	533MHz
Cache Memory	L1 Cache: 64KB L2 Cache: 2MB (on CPU)
Main Memory	1GB DDR2 SDRAM (512MB on board, upgradeable up to 1.5GB)*2 1 SO-DIMM slot (The pre-installed memory module uses one)
Hard Disk	80GB (C: 30GB, D: 45GB, HDD recovery storage: 5GB)*3 Ultra ATA/100
Optical Drive	DVD±RW Drive (supporting DVD+R DL)*4 Maximum reading speed: DVD+R, DVD-R, DVD+RW, DVD-RW, DVD+R DL: 4x / DVD-ROM: 8x / CD-RW: 12x / CD-R, CD-ROM: 24x Maximum writing speed: DVD-RW: 2x / DVD+R DL, DVD+RW: 2.4x / DVD+R, DVD-R: 4x / CD-RW: 10x / CD-R: 24x
Graphics Accelerator	Intel® Graphics Media Accelerator 950
Video Memory	Maximum 128MB (shared with main memory)
Display	11.1" Wide (WXGA: 1366 x 768) TFT colour display (Clear Bright LCD: White LED, Wide View)
Interfaces	• USB 2.0 x 2*5 • i.LINK (IEEE 1394) S400 (4 pin) • Network (RJ-45) connector (100BASE-TX/10BASE-T) • Headphone jack (stereo mini) • Microphone jack (stereo mini) • Monitor connector (VGA, D-SUB 15 pin) • Modular (RJ-11) connector • Port Replicator connector • Memory Stick slot*6 (Standard/Duo Size compatible, MagicGate compatible, Memory Stick PRO compatible, High-speed data transfer compatible) • SD Memory Card slot*7 (MMC card compatible)
Wireless LAN	• Integrated Wireless LAN IEEE 802.11a/802.11b/802.11g*8 • Intel® PRO/Wireless 3945ABG Network Connection • Data rate: maximum 11Mbps (802.11b)/54Mbps (802.11a/g)*9 • Frequency: 5GHz (802.11a), 2.4GHz (802.11b/g)
Security Chip	TCG Ver 1.2 compliant Trusted Platform Module (TPM)
Fingerprint Sensor	Built-in Fingerprint Sensor
Bluetooth®	• Bluetooth® standard version 2.0+EDR*9 • Output: maximum +6dBm • Frequency: 2.4GHz
Modem	V.92 and V.90 compliant
PC Card Slot	Type I/II x 1, CardBus support
Audio	• Intel® High Definition Audio compatible • 3D audio (Direct Sound 3D support) • Built-in stereo speakers
Keyboard / Input Device	• 17mm Key pitch / 1.7mm Key stroke • 82 Keys • Intelligent Touchpad
Battery	VGP-BPS5A*10 Lithium-ion battery: up to 9.5 hours of use*11
Dimensions (W x H x D)	272.4 x 21-28.5 x 195.1mm
Weight	1.25kg (including the supplied battery)
Software Applications	• Adobe Reader 7 • Adobe Photoshop Elements 4.0 (Installer) • Adobe Premiere Elements 2.0 • Click to DVD 2.5 • DVgate Plus 2.2 • Image Converter 2 Plus • Infineon TPM Professional Package 2.5 (Installer) • Instant Mode 1.1 • Norton Internet Security 2006 • Roxio DigitalMedia SE 7 • Protector Suite QL 5.3 • PictureGear Studio 2.0 • SonicStage 3.4 • SonicStage Mastering Studio 2.2 • SonicStage Mastering Studio Audio Filter 2.0 • VAIO Control Center 1.1 • VAIO Edit Components 6.0 • VAIO HDD Protection 1.1 • VAIO Media 5.0 • VAIO Original Screen Saver • VAIO Recovery Utility 2.6 • VAIO Update 2.1 • VAIO Zone 1.4 • WinDVD 5 for VAIO
Supplied Accessories	• AC adapter (VGP-AC16V8) • Lithium-ion battery (VGP-BPS5A) • Headphone (MDR-Q22LP/S02)
Warranty	One year*12

Features and specifications are subject to change without notice.

*1 CPU speed will be reduced under certain operating conditions. *2 By removing the pre-installed 512MB memory module and adding one 1GB memory module. *3 Necessary data for recovery (setting back to initial shipment settings) in the hard disk drive consuming approximately 5GB in size is available separately. *4 This product is designed to playback discs that conform to the Compact Disc Digital Audio standard specifications (CD Standard). A DualDisc is a two sided disc product which mates DVD recorded material on one side with digital audio material on the other side. Please be aware that the audio side (non-DVD side) of a DualDisc may not play on this product because it does not conform to the CD Standard. *5 High-speed/Full-speed/Low speed compatible. *6 Compatibility confirmed with Sony branded "Memory Stick" media only. *7 Does not support SD card's copyright technology. *8 Deploying IEEE 802.11b and IEEE 802.11g products on the same wireless network may reduce the communication speed due to radio interference. Taking this into consideration, the IEEE 802.11g products are designed to reduce the communication speed to ensure communication with IEEE 802.11b products. When the communication speed is not as fast as expected, changing the wireless channel on the access point may increase the communication speed. *9 The communication speed varies depending on the distance between communication devices, existence of obstacles between such devices, the device configuration, the radio conditions, and the software in use. In addition, communication may be cut off depending on the radio conditions. *10 This product may only function with a genuine Sony battery designed for this model. *11 Estimated battery life (under JEITA Battery Run Time Measurement Method (ver.1.0).) When the power-saving mode is on. Actual battery life may vary with different operating conditions and settings. For further details, please visit vaio-online.sony.com *12 Warranty conditions may vary by region.

The trademarks, including but not limited to "SONY", "VAIO", "Memory Stick" and "SonicStage" are either trademarks or registered trademarks of Sony Corporation and/or its subsidiaries. Adobe, Adobe Photoshop, Adobe Reader and Adobe Premiere are trademarks of Adobe Systems Incorporated in the United States and/or other countries. Intel, Intel Inside, the Intel Inside logo, the Centrino logo, Centrino, Intel SpeedStep, Pentium, and Pentium Inside are trademarks or registered trademarks of Intel Corporation or its subsidiaries in the United States and other countries. Microsoft and Windows are either trademarks or registered trademarks of Microsoft Corporation in the United States and other countries. All other product and brand names may be trademarks or registered trademarks of their respective owners. Whilst information given is true at time of printing, small production changes in the course of our company's policy of improvement through research and design might not necessarily be included in the specifications. E&OE. Actual models may differ slightly in appearance to illustrations provided.



Windows Vista™ Capable PC

Buying a new PC that is Windows Vista™ Capable enables you to upgrade, once available, to the next version of Microsoft® Windows® and the future of computing.

For more information, please access:
<http://www.css.ap.sony.com/vaio/vista>

This product is Windows Vista™ Capable PC.

Optional Accessories for VGN-TX37GP/W (availability depends on region)

VGP-PRTX1 Port Replicator

- DC-IN
- Monitor connector (VGA, D-SUB 15 pin)
- Network connector
- USB 2.0 connector (x3)



VGP-BPL5A Lithium-ion Battery

- Rechargeable battery
- Up to 16 hours battery life*11



VGP-UMS50 USB Optical Mouse

- Stylish, easy-to-use sloping design
- Innovative PTFE sole for precise operation
- Sensor resolution: 800 dots per inch



VGP-CKTX1 Carrying Case

- Perfect size for VAIO TX
- Ideal slim, lightweight PC case
- Seven layer cushioning fabric
- Soft, luxurious feel in hand



VGN-TX37GP/W

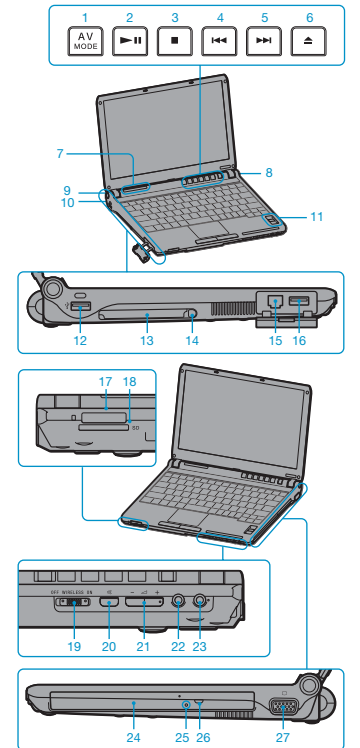

1. AV Mode button
2. Play/Pause button
3. Stop button
4. Previous track button
5. Next track button
6. Disc eject button
7. Indicators
8. Network (RJ-45) connector (100BASE-TX/10BASE-T)
9. DC-IN connector
10. i.LINK (IEEE1394) S400 (4 pin) connector
11. Fingerprint sensor
12. USB 2.0 connector
13. PC Card Slot (Type I/II x 1)
14. PC Card eject button
15. Modular (RJ-11) connector
16. USB 2.0 connector
17. Memory Stick slot (Standard/Duo Size compatible, MagicGate compatible, Memory Stick PRO compatible, high-speed data transfer compatible)
18. SD card slot (MMC card compatible)
19. Wireless LAN switch
20. Mute button
21. Volume buttons
22. Headphone jack (stereo mini)
23. Microphone jack (stereo mini)
24. DVD±RW drive (supporting DVD+R DL)
25. Manual eject hole
26. Disc eject button
27. Monitor connector (VGA, D-SUB 15 pin)

vaio-online.sony.com



Sony recommends Microsoft® Windows® XP Professional.

Powerful software for creative minds.

DVD CREATION

With Click to DVD, you're only a click away from creating your own photo, movie + photo, or video DVD on DVD±R/RW or DVD+R DL disc. You can also create 5.1 surround sound DVDs. Moreover, Roxio DigitalMedia SE lets you back up audio, image, and data files on CDs and DVDs.



Roxio DigitalMedia SE

CONTENT BROWSER

VAIO Zone lets you seamlessly enjoy CDs, DVDs, music, photos, videos and other AV files through a single interface. And VAIO Media software enables AV files on your VAIO to be accessed and played by other VAIO Media-installed VAIO notebooks and PCs on your home network.



VAIO Media

MOVIES

Import videos from a Handycam*, trim and edit them, or export them to a Handycam* with DVgate Plus. Use Adobe® Premiere® Elements with VAIO Edit Components to add transitions and effects like sparkles.



Adobe® Premiere® Elements

PHOTOS

Import images from your digital camera via USB cable or Memory Stick, then edit the files with Adobe® Photoshop® Elements. Use PictureGear Studio to place them in chronological order with Calendar View, create a slideshow, or create a photo album and print it or attach it to email.



PictureGear Studio

MUSIC

Import music from the Net or CDs with SonicStage. Then transfer it to a Network Walkman* or burn your own original CDs. SonicStage Mastering Studio lets you import analogue music (Roland EDIROL AUDIO capture UA-25* or UA-101* USB audio interface device required) and edit it with high-quality effector modules before recording on a CD. SonicStage Mastering Studio Audio Filter can enhance any sound played on VAIO and provides excellent headphone presets.

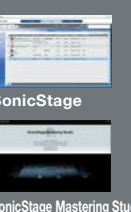

SonicStage Mastering Studio



SonicStage Mastering Studio Audio Filter



Unique AV buttons



VAIO mirror logo



Comfortable keyboard



Convenient fingerprint recognition
Frontal headphone jack
Convenient Mute button and Volume buttons

Empower your elegant mobile lifestyle. VGN-TX37GP/W

A stylish mobile notebook PC with slim dimensions and attractive platinum white casing, the VAIO TX37GP/W is every bit as attractive as it is powerful. Impressive Intel® Centrino® Mobile Technology and built-in wireless capabilities deliver the business performance you need on the move, and a range of design details add further convenient elegance. Leading security features help secure your data in the office and on the move. Innovative functions make for smoother, simpler AV enjoyment and DVD creation, and a surprisingly light weight makes it great for carrying virtually anywhere. A mobile notebook PC with style and performance — that's the VAIO TX37GP/W.

Sophisticated style you'll want to carry everywhere

Ultra portable and exceptionally attractive, the VAIO TX37GP/W exudes sophisticated innovation. Minimal weight and appealing dimensions are achieved with advanced carbon materials, and the display cabinet is made especially slim through the use of white LEDs. A unique "gravity-joint" design confers a confident sense of balance between screen and keyboard, and attractive platinum white casing provides protective elegance. Packing the style and the power to complement the way you live, it's a mobile achievement you'll want to carry everywhere.

Powerful mobility

The VAIO TX37GP/W gives you powerful performance on the move. Its VGP-BPS5A battery delivers up to 9.5 hours* of productivity, while the optional VGP-BPL5A battery delivers up to an impressive 16 hours*. Proven performance is underscored by impressive Intel® Centrino® Mobile Technology comprising an Intel® Core™ Solo Processor U1400 (1.20GHz), an Intel® 945GMS Express Chipset and Intel® PRO/Wireless 3945ABG Network Connection. Wireless LAN a/b/g capability is built-in as standard, and Bluetooth® headset support adds versatile communicative capability.

* Estimated battery life under JEITA Battery Run Time Measurement Method (ver.1.0) when the power-saving mode is on. Actual battery life may vary with different operating conditions and settings.

Recommended headset
Sony Ericsson HBH-608*



Security for assured mobility

VAIO TX37GP/W has many security features to prevent unauthorised access and ensure your mobile PC lifestyle. Hard Disk Password protects sensitive HDD data for one level of security. The biometric fingerprint sensor allows for another, with easy yet unmistakable ID recognition, circumventing the need for passwords. Further data protection for your VAIO TX37GP/W comes from secure encryption and decryption of files and folders via the Trusted Platform Module (TPM) security chip and bundled software utility.

An excellent 11.1" wide AV experience

Despite being so surprisingly slim, the VAIO TX37GP/W is big on entertainment. Employing white LEDs for the backlight, the 11.1" wide LCD (16:9 / WXGA: 1366 x 768) delivers excellent DVD viewing performance beyond its weight and dimensions. Instant Mode can be activated at the press of a button, so you can enjoy CDs and DVDs without waiting to boot up. Furthermore, the SonicStage Mastering Studio Audio Filter enables excellent audio production through recommended headphones (for example, MDR-Q22LP/S02 supplied with VAIO TX37GP/W). DVD±RW writing capability (supporting DVD+R DL) adds to options for creative output. Impressive, entertaining, inspiring — that's the VAIO TX37GP/W.



+ Main features

DVD video recording: One-Click DVD Video Creation	Beautiful viewing: Clear Bright LCD (White LED, Wide View) / Wide 16:9	Ultra light weight: 1.25kg	Network freedom: Wireless LAN 802.11 a/b/g	Cable-free: Bluetooth®	Superior material: Carbon Body	Handy presentation: Plug & Display
Instant ID recognition: Fingerprint Sensor	Assured security: TPM Security Chip / Hard Disk Password	Scratch prevention: VAIO HDD Protection	Content sharing: Memory Stick Slot (Standard/Dual/MagicGate/PRO compatible) / SD Card Slot	Simple entertainment access: AV Control Buttons	Theatre sound quality: Dolby Virtual Speaker / Dolby Headphone	Optional accessory: Port Replicator

+ Basic specifications

Intel® Core™ Solo Processor U1400 (1.20GHz)	Microsoft® Windows® XP Professional	11.1" WXGA 1366 x 768 LCD	DVD±RW Drive (supporting +R DL)	1GB (DDR2) Main Memory	80GB Hard Disk Drive
---------------------------------------------------	-------------------------------------------	------------------------------	------------------------------------	---------------------------	-------------------------

Sony's recommended headphones* for VAIO

Inner, Open-air MDR-E931LP	Supplied with VAIO TX37GP/W
Inner, Closed MDR-EX51LP	
Overhead, Closed MDR-V700DJ	

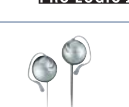

VAIO provides an audio filter adjusted exclusively for the recommended headphones. Created at a professional music studio, this filter ensures superlative quality sound reproduction. * Availability depends on region.



* Availability depends on region.
Note: Any copying or reproduction of copyrighted material may amount to copyright infringement. Song titles, names of artists and other information shown in the SonicStage screen capture are provided for illustrative purposes only.